

Simon XT Installation Manual

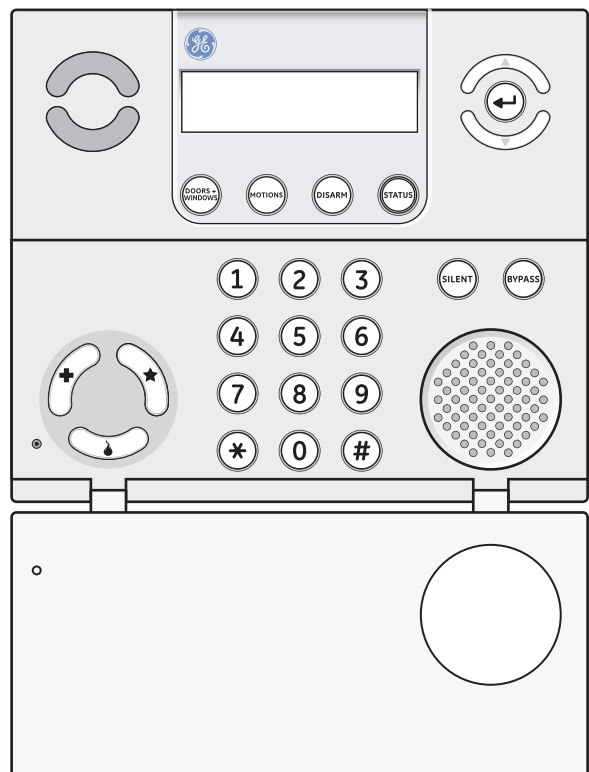
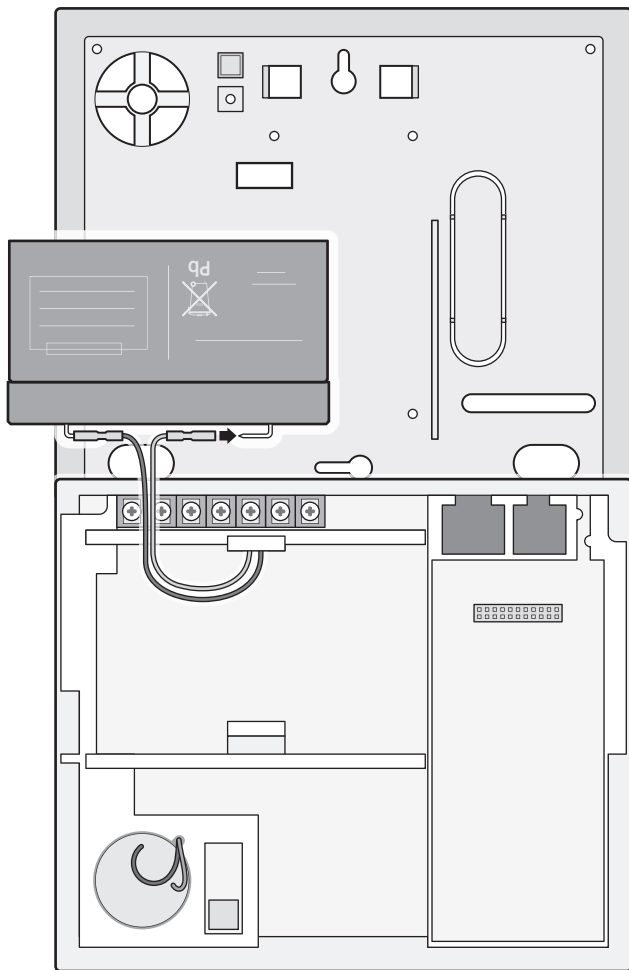

Copyright Copyright © 2007 GE Security. All rights reserved.
This document may not be copied in whole or in part or otherwise reproduced without prior written consent from GE Security except where specifically permitted under US and international copyright law.
Document number: **466-2265B** (June 2007).

Disclaimer The information in this document is subject to change without notice. GE Security, Inc. ("GE Security") assumes no responsibility for inaccuracies or omissions and specifically disclaims any liabilities, losses, or risks, personal or otherwise, incurred as a consequence, directly or indirectly, of the use or application of any of the contents of this document. For the latest documentation, contact your local supplier or visit us online at www.gesecurity.com.
This publication may contain examples of screen captures and reports used in daily operations. Examples may include fictitious names of individuals and companies. Any similarity to names and addresses of actual businesses or persons is entirely coincidental.

Trademarks and patents GE and the GE monogram are registered trademarks of General Electric Company.
Simon and Simon XT are trademarks of GE Security.
Other trade names used in this document may be trademarks or registered trademarks of the manufacturers or vendors of the respective products.
This product and the use of this product may be covered by one or more of the following patents: 5,805,063; 5,872,512; 5,942,981; 5,686,896; 5,686,885; or 4,855,713.

Software license agreement **Important:** This end-user license agreement ("Agreement") is a legal agreement between GE SECURITY and You. Read the following terms and conditions carefully before installing or using this Software. This agreement provides a license from GE SECURITY to use the Software. It also contains warranty information, disclaimers, and liability limitations. Installing and/or using the Software confirms Your agreement to be bound by these terms and conditions. If You do not agree with these terms and conditions, do not install or use the Software or, if already installed, immediately cease all use of the Software and promptly uninstall all components of the Software.

1. Definitions. The following definitions apply to this document:

- a. "GE SECURITY", with respect to title to or warranty of the Software, means GE Security Inc., a Delaware corporation.
- b. "Software" mean the executable software or firmware programs and accompanying documentation installed on the GE SECURITY products, plus any upgrades, modified versions, updates, additions, and copies of the software furnished to Customer during the term of the license granted herein.
- c. "Documentation" means all associated media, printed materials, and electronic documentation accompanying the Software.
- d. "Licensed Product" means the Software and Documentation.
- e. "Customer" means the person or organization, or parent or subsidiary thereof, who uses the Software for its intended purposes, and excludes distributors, authorized resellers, value-added resellers and original equipment manufacturers. Customer may be referred to as You or Your, whether an individual or a business entity of any kind.
- f. "Machine" means the computer, workstation, terminal, or other hardware product on which the Software is installed.

2. License. All rights to and in the Licensed Product, including, but not limited to, copyrights, patents, trademarks, and trade secrets, belong to GE SECURITY, and GE SECURITY retains title to each copy of the Software. You agree that GE SECURITY at any time, upon reasonable notice, may audit Your use of the Software for compliance with the terms and conditions of this Agreement. Subject to the terms and conditions of this Agreement, GE SECURITY grants You a nonexclusive license to use the Software, but only in the country where acquired, provided that You agree to the following:

You may:

- a. install and use the Software on a single Machine at one time, unless You have purchased additional copies of the Software, in which case You may install the software on the number of Machines for which You have purchased copies of the Software;
- b. use the original copy of the Software provided to You for backup purposes.

You may not:

- a. transfer or distribute the Licensed Product to others, in electronic format or otherwise, and this Agreement shall automatically terminate in the event of such a transfer or distribution;
- b. use the Software over a computer network;
- c. sell, rent, lease, or sublicense the Software;
- d. copy or modify the Licensed Product for any purpose, including for backup purposes.

3. Term. This Agreement is effective until terminated. You may terminate this Agreement by uninstalling all components of the Software from all Machines and returning the Software to GE SECURITY. GE SECURITY may terminate this Agreement if You breach any of these terms and conditions. Upon termination of this Agreement for any reason, You agree to uninstall all components of the Software and return the Licensed Product to GE SECURITY. All provisions of this Agreement relating to (i) disclaimer of warranties; (ii) limitations on liability, remedies, and damages; and (iii) GE SECURITY's proprietary rights, shall survive termination of this Agreement.

4. Object code. The Software is delivered in object code only. You may not alter, merge, modify, adapt, or translate the Software, nor decompile, disassemble, reverse-engineer, or otherwise reduce the Software to a human-perceivable form, nor create derivative works or programs based on the Software.

5. Limited warranty. GE SECURITY warrants that for one (1) year from the date of delivery of the Licensed Product (Software Warranty Period), the functions contained in the Software will be fit for their intended purpose as described in the applicable Documentation from GE SECURITY, and will conform in all material respects to the specifications stated in such Documentation. GE SECURITY does not warrant that the operation of the Software will be uninterrupted or error-free. GE SECURITY does warrant that the media on which the Software is furnished will be free from defects in materials and workmanship under normal use for a period of thirty (30) days from the date of delivery (Media Warranty Period). Except as specifically provided therein, any other software and any hardware furnished with or accompanying the Software is not warranted by GE SECURITY.

Your exclusive remedy under this limited warranty for nonconforming Software shall be repair or replacement of the Software, at the sole discretion of GE SECURITY. To obtain a repair or replacement of nonconforming Software, contact GE SECURITY Customer Service toll-free at 888-GESECURITY or online at www.gesecurity.com during the Software Warranty Period.

Except as expressly provided above, the licensed product is provided "as is" without warranty of any kind, either expressed or implied, including, but not limited to, implied warranties of merchantability or fitness for a particular purpose and, except as expressly provided above, You assume the entire risk as to the quality and performance of the licensed product.

6. Limitation of liability. GE SECURITY's sole obligation or liability under this agreement is the repair or replacement of nonconforming software and/or defective media according to the limited warranty above. In no event will GE SECURITY be liable for damages, whether consequential, incidental, or indirect, nor for loss of data, loss of profits, or lost savings, arising from use or inability to use the software or documentation (or any hardware furnished with the software), even if GE SECURITY has been advised of the possibility of such damages, nor for any claim by any third party.

7. General. Any materials provided to You by GE SECURITY shall not be exported or reexported in violation of any export provisions of the USA or any other applicable jurisdiction. Any attempt to sublicense, assign, or transfer any of the rights, duties, or obligations hereunder shall be void. This Agreement shall be governed by and interpreted under the laws of the State of New York, United States of America, without regard to conflicts of law provisions. You hereby consent to the exclusive jurisdiction of the state and federal courts located in Multnomah County, Oregon, to resolve any disputes arising under or in connection with this Agreement, with venue in Portland, Oregon.

8. Restricted rights legend. The Licensed Product is provided with RESTRICTED RIGHTS. In the event the United States Government or an agency thereof is granted a license, the following additional terms apply: Restricted Computer Software, as defined in the Commercial Computer Software–Restricted Rights clause at Federal Acquisition Regulations 52.227-19, and the restrictions as provided in subparagraphs (c)(1) and (c)(2) thereof; and as applicable, the Government's rights to use, modify, reproduce, release, perform, display, or disclose the Software also are restricted as provided by paragraphs (b)(2) and (b)(3) of the Rights in Noncommercial Technical Data and Computer Software–Small Business Innovative Research (SBIR) Program clause at DFARS 252.227-7018.

9. Acknowledgment. You acknowledge that You have read and understand this agreement and agree to be bound by its terms. You further agree that this agreement is the complete and exclusive statement of the agreement between You and GE SECURITY, and supersedes any proposal or prior agreement, oral or written, and any other communication relating to the subject matter of this agreement.

Intended use	Use this product only for the purpose it was designed for; refer to the data sheet and user documentation. For the latest product information, contact your local supplier or visit us online at www.gesecurity.com .
FCC compliance	Changes or modifications not expressly approved by GE Security can void the user's authority to operate the equipment. This equipment has been tested and found to comply with the limits for a Class B digital device, pursuant to part 15 of the FCC Rules. These limits are designed to provide reasonable protection against interference in a residential installation. This equipment generates, uses, and can radiate radio frequency energy and, if not installed and used in accordance with the instructions, may cause harmful interference to radio communications. However, there is no guarantee that interference will not occur in a particular installation. If this equipment does cause harmful interference to radio or television reception, which can be determined by turning the equipment off and on, the user is encouraged to try to correct the interference by one or more of the following measures:

Reorient or relocate the receiving antenna.
Increase the separation between the equipment and receiver.
Connect the affected equipment and the panel receiver to separate outlets, on different branch circuits.
Consult the dealer or an experienced radio/TV technician for help.

ACTA Part 68

This equipment complies with Part 68 of the FCC rules. Located on this equipment is a label that contains, among other information, the FCC registration number and the ringer equivalence number (REN) for this equipment. If requested, this information must be provided to the telephone company.

FCC Part 68 registration number: US:B4ZAL02B55910.

The REN is used to determine the maximum number of devices that may be connected to your telephone line. Excessive RENs on a telephone line may result in devices not ringing in response to an incoming call. In most areas, the sum of all device RENs should not exceed five (5.0). To be certain of the number of devices that may be connected to a line, as determined by the total RENs, contact the local telephone company. For products approved after July 23, 2001, the REN for this product is part of the product identifier that has the format US:AAAEQ##TXXXX. The digits represented by ## are the REN without a decimal point (e.g., 03 is a REN of 0.3). For earlier products, the REN is separately shown on the label.

A plug and jack used to connect this equipment to the premises wiring and telephone network must comply with the applicable FCC Part 68 rules and requirements as adopted by ACTA. A compliant telephone cord and modular plug is provided with this product. It is designed to be connected to a compliant modular jack that is also compliant. See the Installation Instructions for details.

Alarm dialing equipment must be able to seize the telephone line and place a call in an emergency situation. It must be able to do this even if other equipment (telephone, answering system, computer modem, etc.) already has the telephone line in use. To do so, alarm dialing equipment must be connected to a properly installed RJ31X jack that is electrically in series and ahead of all other equipment attached to the same telephone line. If you have any questions concerning these instructions, consult your local telephone company or a qualified installer about installing an RJ31X jack and alarm dialing equipment for you.

If this equipment causes harm to the telephone network, the telephone company may temporarily disconnect your service. If possible, you will be notified in advance. When advance notice is not practical, you will be notified as soon as possible. You will also be advised of your right to file a complaint with the FCC.

The telephone company may make changes in its facilities, equipment, operations, or procedures that could affect the operation of the equipment. You will be given advance notice in order to maintain uninterrupted service.

If you experience trouble with this equipment, please contact the company that installed the equipment for service and/or repair information. The telephone company may ask you to disconnect this equipment from the network until the problem has been corrected or you are sure that the equipment is not malfunctioning. This equipment may not be used on coin service provided by the telephone company. Connection to party lines is subject to state tariffs.

EMC directive

The European Union directive on electromagnetic compatibility (2004/108/EC) requires non-European manufacturers to designate an authorized representative in the Community. Our European representative is GE Security, Kelvinstraat 7, 6003 DH Weert, Nederland.



The European directive *Waste Electrical and Electronic Equipment (WEEE)* aims to minimize the impact of electrical and electronic equipment waste on the environment and human health. For proper treatment, recovery, and recycling, return the equipment marked with this symbol to your local supplier upon the purchase of equivalent new equipment, or dispose of it in designated collection points. For more information, visit www.recyclethis.com.

Contents

	Tables	vii
	Preface	ix
	Conventions used in this document	ix
	Safety terms and symbols	ix
	Materials needed	ix
Chapter 1.	Introduction	1
	Product overview	2
	System components	3
	Standard panel	4
Chapter 2.	Planning	5
	Planning the installation	6
	Control panel location	6
	Planning sensor types and locations	6
	System configuration	11
	Emergency planning	16
Chapter 3.	Installing the system	17
	Opening panel cover and chassis	18
	Mounting the panel	19
	Connecting hardwired devices	20
	HW1 I/O, HW2 in, and HW1&2 DC out terminals	20
	Interior sirens	20
	LD105 hardwired interior siren	21
	Hardwired contacts	22
	Wiring a phone line to the panel	23
	Full line seizure	23
	Wiring the power transformer	26
	Powering up the panel	26
	Installing X10 modules	28

Chapter 4.	Programming	29
	Programming overview	30
	Entering and exiting the system menu.....	31
	Menu navigation	32
	Set clock	34
	Revision	34
	Contrast	34
	System programming	35
	Access codes.....	35
	Security	36
	Phone numbers	37
	Phone options	38
	Sensors	39
	Reporting	41
	Timers	44
	Touchpad options	45
	System options.....	46
	Siren options	47
	Piezo beep options.....	48
	Audio verification options	49
	Light control (optional)	50
	System tests	52
	Resetting memory to the factory defaults.....	53
Chapter 5.	Testing	55
	Control panel	56
	Sensor testing	57
	If a sensor fails the sensor test	58
	Phone communication.....	59
	Offsite phone operation.....	59
	Central station communication.....	60
	Two-way voice operation	61
	Voice event notification	61
	X10 operation	62
	Manual lamp module control.....	62
	X10 siren and lamp module functions	62
Chapter 6.	Troubleshooting and support.....	63
	Troubleshooting.....	64
	Contacting technical support.....	66
	Online publication library	66
Appendix A.	Specifications and tables.....	67
	Specifications	68
	Sensor names.....	68
Index	71

Tables

Table 1.	Supported devices	3
Table 2.	Panel hardware capabilities.....	4
Table 3.	Recommended sensor groups.....	7
Table 4.	Sensor group characteristics.....	7
Table 5.	Sensor assignments/locations.....	9
Table 6.	System programming menu options.....	11
Table 7.	Simon XT panel keys and features	31
Table 8.	Simon XT menu structure.....	32
Table 9.	Simon XT programming codes	35
Table 10.	Access codes.....	35
Table 11.	Security	36
Table 12.	Phone numbers.....	37
Table 13.	Phone options	38
Table 14.	Device programming.....	39
Table 15.	Sensors.....	41
Table 16.	Reporting options.....	41
Table 17.	Communication modes.....	43
Table 18.	Timers	44
Table 19.	Touchpad options	45
Table 20.	System options.....	46
Table 21.	Siren options.....	47
Table 22.	Panel piezo beeps	48
Table 23.	Audio verification.....	49
Table 24.	Light control.....	52
Table 25.	System tests	52
Table 26.	Control panel test sequence.....	56
Table 27.	Arming levels.....	56
Table 28.	Sensor tripping instructions	57
Table 29.	Minimum beeps.....	58
Table 30.	Phone commands.....	59
Table 31.	Sensor/user report codes.....	60
Table 32.	Audio verification set.....	61
Table 33.	Alarm siren and X10 light information	62
Table 34.	Service and support contact information.....	66
Table 35.	Simon XT specifications	68
Table 36.	Alphabetical list of sensor name segments.....	68
Table 37.	Sensor name segments by index number (in scrolling order)	69
Table 38.	Simon XT system quick reference	70

Preface

This is the GE *Simon XT Installation Manual*. This document includes an overview of the product and detailed instructions explaining:

- how to install; and
- how to set up the product for customer use.

There is also information describing how to contact technical support if you have questions or concerns.

To use this document effectively, you should have a basic knowledge of electrical wiring and low-voltage electrical connections.

Read these instructions and all ancillary documentation entirely before installing or operating this product. The most current versions of this and related documentation may be found on our website. Refer to [Online publication library](#) on page 66 for instructions on accessing our online publication library.

Note: A qualified service person, complying with all applicable codes, should perform all required hardware installation.

Conventions used in this document

The following conventions are used in this document:

Bold	Menu items and buttons.
<i>Italic</i>	Emphasis of an instruction or point; special terms.
	File names, path names, windows, panes, tabs, fields, variables, and other GUI elements.
	Titles of books and various documents.
<i>Blue italic</i>	(Electronic version.) Hyperlinks to cross-references, related topics, and URL addresses.
Monospace	Text that displays on the computer screen.
	Programming or coding sequences.

Safety terms and symbols

These terms may appear in this manual:



CAUTION: *Cautions* identify conditions or practices that may result in damage to the equipment or other property.



WARNING: *Warnings* identify conditions or practices that could result in equipment damage or serious personal injury.

Materials needed

- Pencil
- Phillips screwdriver

Chapter 1 Introduction

This chapter provides an overview of the system and an outline of the steps you need to perform before you begin installing and configuring your security system.

In this chapter:

<i>Product overview</i>	2
<i>System components</i>	3
<i>Standard panel</i>	4

Product overview

This security system can be used as a fire warning system, an intrusion alarm system, an emergency notification system, or any combination of the three. The system (*Figure 1*) has three types of components:

- Self-contained control panel
- Devices that report to the panel
- Devices that respond to commands from the panel

Figure 1. Simon XT system

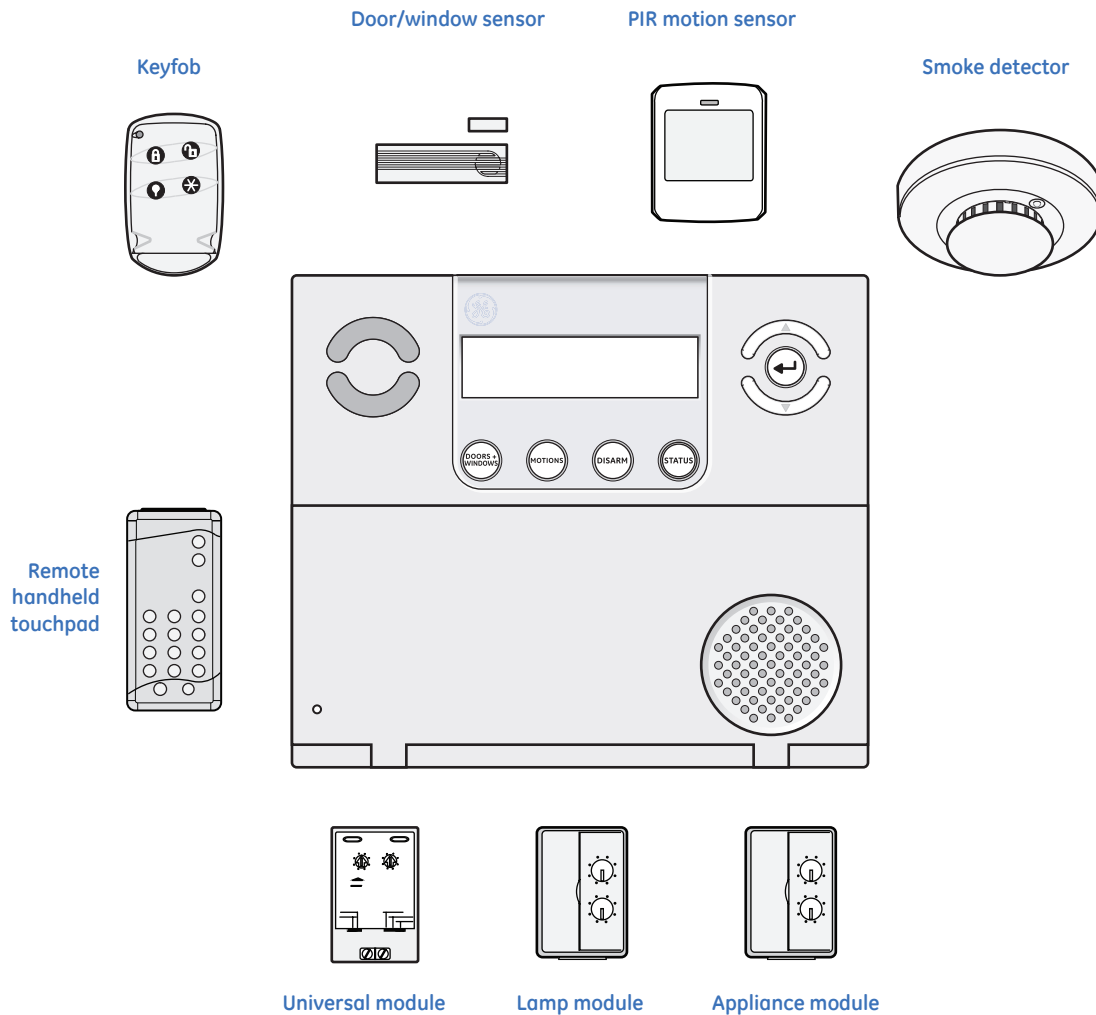

Note: The universal, lamp, and appliance modules require a special transformer.

The self-contained panel provides the main processing unit for all system functions. It receives and responds to signals from wireless sensors and wireless touchpads throughout the premises. For monitored systems, the panel can be connected to the premises phone line for central monitoring station reporting.

You can program the panel onsite from the keypad or remotely using Enterprise Downloader software. See [Programming](#) on page 29 for complete onsite programming instructions.

System components

The system can monitor up to 40 sensors and may use any of the devices listed in *Table 1*.

Table 1. Supported devices

Device	Description
Door/window sensor (60-670)	For intrusion protection, install door/window sensors on all ground-floor doors and windows. At a minimum, install them in the following locations: <ul style="list-style-type: none"> • All easily accessible exterior doors and windows. • Interior doors leading into the garage. • Doors to areas containing valuables such as cabinets and closets.
Indoor motion sensor (60-639)	Indoor motion sensors are ideal whenever it is not practical to install door/window sensors on every opening. Identify areas where an intruder is likely to walk through. Large areas in an open floor plan, downstairs family rooms, and hallways are typical locations for indoor motion sensors. For installations with pets, use the SAW Pet Immune PIR (60-807).
Outdoor motion sensor (60-639)	Use outdoor motion sensors to detect motion in a protected outdoor area. Detected motion in this protected area can sound chimes or turn on outside lights.
X10 module	When the panel is powered using the line carrier power transformer, the system can work with any of the following modules: <ul style="list-style-type: none"> • X10 lamp module (13-403) • X10 appliance module (13-402) • X10 power horn/remote siren module (13-398) • X10 universal module (13-399)
Freeze sensor (60-742)	Freeze sensors detect low temperature conditions which may indicate a furnace failure. The sensor contains a bimetallic thermal switch connected to the built-in transmitter. The sensor transmits an alarm signal to the panel when the surrounding temperature drops to about 41°F (5°C). When the temperature rises to 50°F (10°C), the sensor transmits a restore signal.
Water sensor (60-744)	Water sensors detect a water leak/rising water. The detector is connected to the sensor by an 8-foot (2.4-meter) cable. Water that reaches both detector contact points activates the sensor, causing it to transmit an alarm signal.
Smoke sensor (60-848-95)	Smoke sensors provide fire protection by causing an alarm to sound throughout the house. You can add smoke sensors near sleeping areas and on every floor of the house. Avoid areas that could have some smoke or exhaust such as attics, kitchens, above fireplaces, dusty locations, garages, and areas with temperature extremes. In these areas you may want to install Rate-of-Rise sensors to detect extreme temperature changes. Emergency planning on page 16 and the instructions packaged with the smoke sensor for complete placement information.
Carbon monoxide (CO) alarm (60-652-95)	The Learn Mode™ CO alarm alerts users to hazardous levels of carbon monoxide gas. If dangerous concentrations of gas are present, the red indicator light comes on, the internal siren goes off, and an alarm is transmitted to the panel. The panel sounds its own alarm and reports to the central station.
Keyfob (60-659)	The keyfob (keychain touchpad) lets you turn the system on and off from right outside the home or activate a panic alarm if there is an emergency. If you have X10 lamp modules, you can use keyfobs to turn all system controlled lights on and off.
ELM (encrypted learn mode) keyfob (60-832)	The ELM (encrypted learn mode™) 2-button keyfob is an alkaline battery-powered, wireless touchpad that allows users to arm and disarm their system, and activate a police or auxiliary panic alarm. Random encrypted signal transmissions provide high security to help prevent signal copying.

Table 1. Supported devices (continued)

Device	Description
Remote handheld touchpad (60-671)	The remote handheld touchpad lets you turn the system on and off while in the home, turn system controlled lights on and off (all or individual lights), or activate a panic alarm if there is a nonmedical emergency.
Water-resistant personal help button (60-906-95)	The water-resistant personal help button is a wireless device used for activating police, medical or auxiliary alarms through your system. When the help button is pressed, the light mounted under the cover will blink and an alarm signal is transmitted.



CAUTION: Do not use outdoor motion sensors for intrusion protection.

Standard panel

Table 2 describes the basic panel (out-of-box) hardware capabilities.

Table 2. Panel hardware capabilities

Hardware	Capability
Power	Input for an AC step-down, plug-in style transformer.
Siren output, two zone inputs	Terminals for connecting hardware sirens or normally closed (NC) loop switch circuits.
Phone line connection	Allows panel to communicate with central monitoring station and/or remote phone.

Inspect the package and contents for visible damage. If any components are damaged or missing, do not use the unit; contact the supplier immediately. If you need to return the unit, you must ship it in the original box.

Chapter 2 Planning

This chapter provides information to help you plan your installation to reduce time and costs.

In this chapter:

<i>Planning the installation</i>	6
<i>Control panel location</i>	6
<i>Planning sensor types and locations</i>	6
<i>System configuration</i>	11
<i>Emergency planning</i>	16

Planning the installation

This section describes system capabilities to help you get familiar with your system. The planning sheets contain tables that let you record the hardware and programming configuration of your system. Complete all of the information ahead of time to help prepare for system installation. Refer to *Sensor names* on page 68 for sensor name segments listed alphabetically and by index number.

Control panel location

Locate the panel where alarm sounds can be heard and where the panel will be easily accessible for operation. Do not install the panel near a window or door where it can be reached easily by an intruder.

Planning sensor types and locations

The first step to an easy and successful installation is to decide what areas or items to protect, which lights or appliances to operate, and the best location for the panel, touchpad, sensors, and sirens.

Metal objects, mirrors, and metallic wallpaper can block signals sent by the wireless sensors. Make sure there are no metal objects in the way when installing the system.

Use *Table 3, Recommended sensor groups* on page 7 and *Table 4, Sensor group characteristics* on page 7 to determine the appropriate sensor type for the sensors you will be adding. Use *Table 5, Sensor assignments/locations* on page 9 to document the planned sensor information. You will need to understand the application for each sensor. For example, keyfobs are typically programmed as sensor group 01 (portable panic) and used to send an intrusion alarm to a central monitoring station. This sensor type is instant intrusion, it does not require restoral or supervisory communication with the panel and it is active in four arming levels:

1. Disarm.
2. Arm doors and windows.
3. Arm motion sensors.
4. Arm doors/windows and motion sensors.

Table 3. Recommended sensor groups

Device	Recommended sensor group
Indoor motion sensor	17 (intrusion), 25 (chime)
Outdoor motion sensor	25 (chime only)
Entry/exit door	10
Interior door	14
Window sensor	13
Smoke Sensor	26
Keyfob	01, 03, 06, 07
ELM keyfob	01, 03, 06, 07
Remote Handheld Touchpad	01, 03, 06, 07
CO Alarm	34
Freeze Sensor	29
Water Sensor	38
Personal Help Button	01, 03

Table 4. Sensor group characteristics

Type	Name/application	Siren type	Delay	Restoral	Supervisory	Active In arming levels
00	Fixed panic: 24-hour audible fixed emergency button.	Intrusion	I	N	Y	1234
01	Portable panic: 24-hour audible portable emergency buttons.	Intrusion	I	N	N	1234
02	Fixed panic: 24-hour silent fixed emergency buttons. Status light will not blink.	Silent	I	N	Y	01234
03	Portable panic: 24-hour silent portable emergency buttons. Status light will not blink.	Silent	I	N	N	01234
04	Fixed auxiliary: 24-hour auxiliary sensor.	Emergency	I	N	Y	01234
05	Fixed auxiliary: 24-hour emergency button. Siren shut off confirms CS report.	Emergency	I	N	Y	01234
06	Portable auxiliary: 24-hour portable auxiliary alert button.	Emergency	I	N	N	01234
07	Portable auxiliary: 24-hour portable auxiliary button. Siren shut off confirms CS report.	Emergency	I	N	N	01234
08	Special intrusion: such as gun cabinets and wall safes. DTM (tamper only).	Intrusion	I	Y	Y	1234
09	Special intrusion: such as gun cabinets and wall safes.	Intrusion	S	Y	Y	1234
10	Entry/exit delay: A delay that requires a standard delay time. chime.	Intrusion	S	Y	Y	24
13	Instant perimeter: Exterior doors and windows. chime.	Intrusion	I	Y	Y	24
14	Instant interior: Interior doors.	Intrusion	F	Y	Y	234

Table 4. Sensor group characteristics (continued)

Type	Name/application	Siren type	Delay	Restoral	Supervisory	Active In arming levels
15	Instant interior: Interior PIR motion sensors.	Intrusion	F	Y	Y	234
16	Instant interior: Interior doors.	Intrusion	F	Y	Y	34
17	Instant interior: PIR motion sensors and Sound sensors.	Intrusion	F	N	Y	34
18	Instant interior: Cross-zone PIR motion sensors.	Intrusion	F	N	Y	34
19	Delayed interior: Interior doors that initiate a delay before going into alarm.	Intrusion	S	Y	Y	34
20	Delayed interior: PIR motion sensors that initiate a delay before going into alarm.	Intrusion	S	N	Y	34
21	Local instant interior: 24-hour local alarm zone protecting anything that opens and closes. No report.	Intrusion	I	Y	Y	1234
22	Local delayed interior: same as group 21, plus activation initiates a delay before going into alarm. No report.	Intrusion	S	Y	Y	1234
23	Local instant auxiliary: 24-hour local alarm zone protecting anything that opens and closes. No report.	Emergency	I	Y	Y	01234
24	Local instant auxiliary: 24-hour local alarm zone protecting anything that opens and closes. Sirens shut off at restoral. No report.	Emergency	I	Y	Y	01234
25	Local special chime: notify the user when a door is opened. Sounds emit from a local annunciator. One direct bypass and unbypass when no special motion chime sensors are in the security system. No report.	Three beeps	I	N	Y	01234
26	Fire: 24-hour fire, rate-of-rise heat, and smoke sensors.	Fire	I	Y	Y	01234
27	Lamp control or other customer feature. No report.	Silent	I	Y	Y	01234
28	PIR motion sensor, sound sensor, or pressure mat. RF thermostat. No report.	Silent	I	N	Y	01234
29	Auxiliary: freeze sensors.	Trouble beeps	I	Y	Y	01234
32	PIR motion sensor or sound sensor. No report.	Silent	I	N	N	01234
34	Carbon monoxide alarm.	Emergency	I	Y	Y	01234
35	Entry/exit delay interior PIR motion.	Intrusion	S	N	Y	234
36	Special Intrusion: such as gun cabinets and wall safes. Reports as tamper if tripped.	Intrusion	I	Y	Y	1234
37	Light switch control: X10 modules turn either on or off when a door is opened.	Silent	I	N	Y	01234
38	Auxiliary: water sensors.	Trouble beeps	I	Y	Y	01234
39	Local instant interior: 24-hour local alarm zone protecting anything that opens and closes. No report.	Intrusion	I	Y	Y	1234
40	Local special chime.	Three beeps	I	Y	Y	01234

Table 5. Sensor assignments/locations

Sensor #	Device	Sensor group	Sensor name/location	Notes
01				
02				
03				
04				
05				
06				
07				
08				
09				
10				
11				
12				
13				
14				
15				
16				
17				
18				
19				
20				
21				
22				
23				
24				
25				
26				
27				
28				
29				
30				

Table 5. Sensor assignments/locations (continued)

Sensor #	Device	Sensor group	Sensor name/location	Notes
31				
32				
33				
34				
35				
36				
37				
38				
39				
40				

Cross-zoning

Cross-zoning (two-trip) refers to two different group 18 sensors that must be tripped within two minutes of each other to report an alarm to the central station. *Figure 2* shows the path of a person walking from the kitchen to the living room. When the person is detected walking through the kitchen, the motion sensor in the kitchen is tripped, sounding a local alarm. If motion is detected by the living room motion sensor within two minutes, an alarm report will be sent to the central station.

Figure 2. Cross-zone diagram

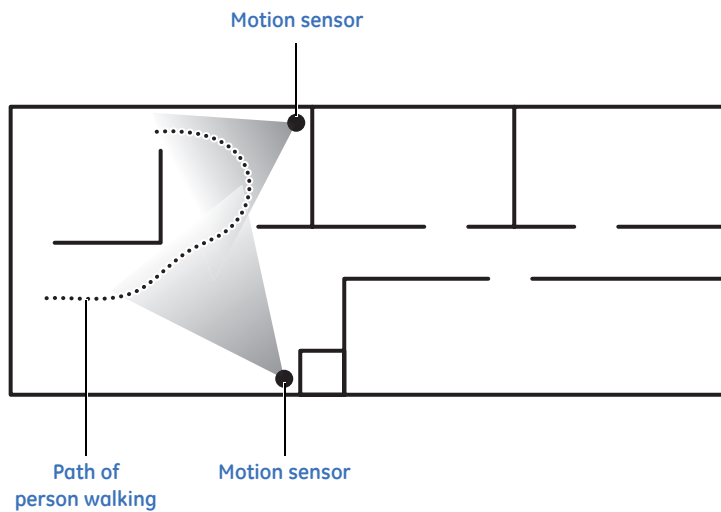

Note: We do not recommend cross-zoning for exit/entry zones. Each zone can individually protect the intended area.

System configuration

Table 6 is a worksheet for you to record the desired values for each programming option. For each option, the default value, effect of deletion (pressing **DISARM** while editing), range, and programming privilege are also listed. Each option is described in more detail in *Chapter 4 Programming* on page 29.

Table 6. System programming menu options

Function	Default	Delete	Range	Access code ^a	Installer settings
Access codes menu					
Dealer code	654321, 54321, 4321, or 321	None	3 to 6 digits	D	
Installer code	654321, 54321, 4321, or 321	None	3 to 6 digits	D, I	
Master code	123456, 12345, 1234, or 123	None	3 to 6 digits	D, I, M	
User code 1	None	None	3 to 6 digits	D, I, M	
User code 2	None	None	3 to 6 digits	D, I, M	
User code 3	None	None	3 to 6 digits	D, I, M	
User code 4	None	None	3 to 6 digits	D, I, M	
User code 5	None	None	3 to 6 digits	D, I, M	
User code 6	None	None	3 to 6 digits	D, I, M	
User code 7	None	None	3 to 6 digits	D, I, M	
User code 8	None	None	3 to 6 digits	D, I, M	
Duress code	None	None	3 to 6 digits	D, I, M	
Code length	4	4	3 to 6	D	
Security menu					
Account number	00000	00000	0 to FFFFFFFF	D, I	
Downloader code	12345	12345	00000 to 99999	D	
Phone lock	Off	Off	On/Off	D	
Autoarm	On	Off	On/Off	D, I	
Exit extension	On	Off	On/Off	D, I	
Secure arming	Off	Off	On/Off	D, I	
No arm low battery	Off	Off	On/Off	D, I	
Quick exit	Off	Off	On/Off	D, I	
Downloader enable	On	Off	On/Off	D, I, M	
Supervisory protest	Off	Off	On/Off	D, I	

Table 6. System programming menu options (continued)

Function	Default	Delete	Range	Access code ^a	Installer settings
Phone # menu					
Phone #1	None	None	26 digits	D	
Phone #2	None	None	26 digits	D	
Phone #3	None	None	26 digits	D, I	
Phone #4	None	None	26 digits	D, I, M	
Downloader number	None	None	26 digits	D, I	
Phone options menu					
Manual phone test	On	Off	On/Off	D, I	
Fail to communicate (must be added for UL listed systems)	On	Off	On/Off	D, I	
DTMF	On (Touchtone)	Off (Pulse)	On/Off	D, I	
300 bps baud rate	On (300 bps)	Off (110 bps)	On/Off	D, I	
Ring/hang/ring	1	Off	1 to 7, Off	D, I	
Dial delay	30 seconds	SIA limits on: 15 sec. SIA limits off: 5 sec.	SIA limits on: 15 to 45 sec. SIA limits off: 5 to 254 sec.	D, I	
Call waiting code	None	None	26 digits	D, I	
Sensors menu					
Learn sensors				D, I	
Delete sensors				D, I	
Edit sensors				D, I	
Reporting menu					
Report options					
Opening reports	Off	Off	On/Off	D, I	
Closing reports	Off	Off	On/Off	D, I	
Forced armed	Off	Off	On/Off	D, I	
AC power failure report (must be added for UL listed systems)	Off	Off	5 to 254 minutes, Off	D, I	
Low CPU battery report (must be added for UL listed systems)	On	Off	On/Off	D, I	
Sensor alarm restoral report	Off	Off	1 to 3, Off	D, I	

Table 6. System programming menu options (continued)

Function	Default	Delete	Range	Access code ^a	Installer settings
24-hour sensor tamper report	Off	Off	On/Off	D, I	
Supervisory/tamper report	Off	Off	On/Off	D, I	
No usage	Off	Off	2 to 254 days, Off	D, I	
Swinger shutdown	On	Off	On/Off	D, I	
Programming report	Off	Off	On/Off	D, I	
Fire alarm verification	Off	Off	On/Off	D, I	
Report communication modes					
Phone 1 report mode	Off	Off	ALL SIA	D	
Phone 2 report mode	Off	Off	ALL CID	D	
Phone 3 report mode	Off	Off	Alarms SIA Alarms CID	D, I	
Phone 4 report mode	Off	Off	Nonalarms SIA Nonalarms CID Backup SIA Backup CID Voice dialer Off	D, I	
Timers menu					
Latchkey time	None	None	12:00 midnight to 11:59 PM, None	D, I, M	
Entry delay	30 sec.	SIA limits on: 30 sec. SIA limits off: 5 sec.	SIA limits on: 30 to 240 sec. SIA limits off: 5 to 240 sec.	D, I	
Exit delay	60 Seconds	SIA limits on: 45 sec. SIA limits off: 5 sec.	SIA limits on: 45 to 254 sec. SIA limits off: 5 to 254 sec.	D, I	
No activity timeout	Off	Off	2 to 24 hours	D, I	
Auto phone test	Off	Off	1 to 254 days	D, I	
Supervisory time	Midnight	None	12:00 midnight to 11:59 PM, None	D, I	
Alarm cancel	6 minutes	Off	6 to 255 minutes, Off	D, I	
RF timeout (supsync)	12 hours	12 hours	2 to 36 hours	D, I	
Fail to open time	Off	Off	12:00 midnight to 11:59 PM, Off	D, I	
Fail to close time	Off	Off	12:00 midnight to 11:59 PM, Off	D, I	
Siren timeout	4 minutes	Off - No timeout	2 to 254 minutes, Off	D, I	

Table 6. System programming menu options (continued)

Function	Default	Delete	Range	Access code ^a	Installer settings
Arming LED shutdown	Off	Off	On/Off	D, I	
Unvacated premises	On	Off	On/Off	D, I	
Smoke supervision	Off	Off	On/Off	D, I	
Touchpad options menu					
Keyfob no delay	Off	Off	On/Off	D, I	
Panic alarms	On	Off	On/Off	D, I	
Remote touchpad arming	Off	Off	On/Off	D, I	
System options menu					
RF Jam detect	Off	Off	On/Off	D, I	
Demo mode	Off	Off	On/Off	D, I	
HW1 function	1	Off	1 - Interior siren output 2 - Output activated when armed 3 - Output activated when disarmed 4 - FTC output (FTC must be on) 5 - Output activated for alarm Off - No output	D	
SIA limits	On	Off	On/Off	D	
24-hour clock	Off	Off	On/Off	D, I	
Siren options menu					
Panel piezo beeps	On	Off	On/Off	D, I, M	
Panel voice	On	Off	On/Off	D, I, M	
Panel piezo alarms (must be added for UL listed systems or a siren must be connected)	On	Off	On/Off	D, I, M	
Trouble beeps (must be added for UL listed systems)	On	Off	On/Off	D, I	
Voice chime	Off	Off	Off - No voice chime 1 - Voice chime (sensor name) 2 - Chime bell 3 - Soft chime bell	D, I	
Status beeps volume	7	7	1 - 10	D, I, M	
Hardwired siren supervision	Off	Off	On/Off	D, I	

Table 6. System programming menu options (continued)

Function	Default	Delete	Range	Access code ^a	Installer settings
Speaker volume	8	8	1 to 8	D, I, M	
Panel silent police panic	Off	Off	On (silent), Off (audible)	D, I	
Panel tamper alarm	Off	Off	On/Off	D, I	
Alarm report verification	Off	Off	On/Off	D, I	
Audio verify menu					
Audio mode	Off	Off	Off - Audio mode disabled 1 - Instant mode 2 - Callback mode	D, I	
Fire shutdown	Off	Off	On/Off	D, I	
Panic talk	Off	Off	On/Off	D, I	
Vox receiver gain	6	6	1 to 32	D, I	
Vox mic gain	24	24	1 to 64	D, I	
Vox mic gain range	64	64	1 to 64	D, I	
Manual mic gain	64	64	1 to 64	D, I	
Light control menu					
Set entry lights	Off	Off	On/Off for each unit number from 1 to 8	D, I, M	
Sensor light	Off	Off	1 to 8, Off	D, I, M	
Light schedule	None	None	HH:MMx for start and stop times, None	D, I, M	
Housecode	A	A	A to O	D, I, M	
Lock interval	None	None	HH:MMx for start and stop times, None	D, I, M	
System test menu					
Sensor test				D, I, M	
Communication test				D, I, M	
System download				D, I, M	

a. This column tells what type of access code is allowed to make changes: D = dealer code, I = installer code, M = master code.

Emergency planning

Use these guidelines when drawing an emergency floor plan for the homeowner:

- Show all building levels.
- Show exits from each room. (We recommend two exits per room.)
- Show the locations of all security system components.
- Show the locations of any fire extinguishers.

Chapter 3 Installing the system

This section describes how to open the panel for mounting, mount the panel, connect sirens, connect hardwired contacts, and connect the AC power transformer.

In this chapter:

<i>Opening panel cover and chassis</i>	18
<i>Mounting the panel</i>	19
<i>Connecting hardwired devices</i>	20
<i>HW1 I/O, HW2 in, and HW1&2 DC out terminals</i>	20
<i>Interior sirens</i>	20
<i>LD105 hardwired interior siren</i>	21
<i>Hardwired contacts</i>	22
<i>Wiring a phone line to the panel</i>	23
<i>Full line seizure</i>	23
<i>Wiring the power transformer</i>	26
<i>Powering up the panel</i>	26
<i>Installing X10 modules</i>	28

Opening panel cover and chassis

Tabs at the top of the panel secure and release the front cover and the chassis. The plastic hinges on the panel bottom allow the cover and chassis to swing down and out of the way (*Figure 3*).

Figure 3. Opening the panel cover and chassis

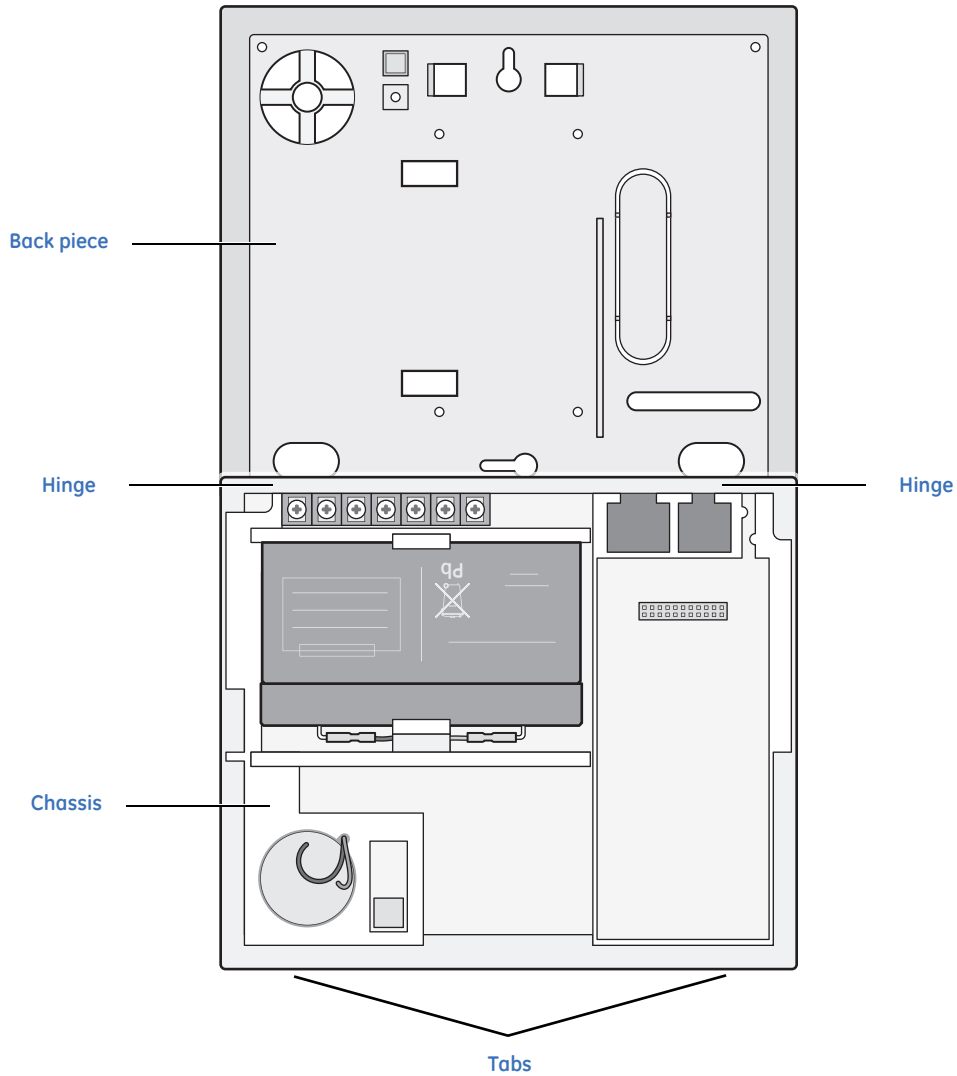

Mounting the panel

To mount the panel on a wall, do the following:

1. Choose a panel location.
2. Run all necessary power, phone, siren, and hardwired contact wires to the desired panel location.
Note: When choosing the AC outlet location for the AC power transformer, make sure the outlet is not controlled by a switch or that it is not part of a ground fault circuit interrupt (GFCI).
3. Hold the panel against the wall and mark the mounting hole locations with a pencil.
4. Mount the back piece to the wall through the two horizontally centered mounting holes near the top and bottom using the supplied mounting hardware. Use wall anchors if no studs are present (*Figure 4*).

Figure 4. Panel mounting hole locations

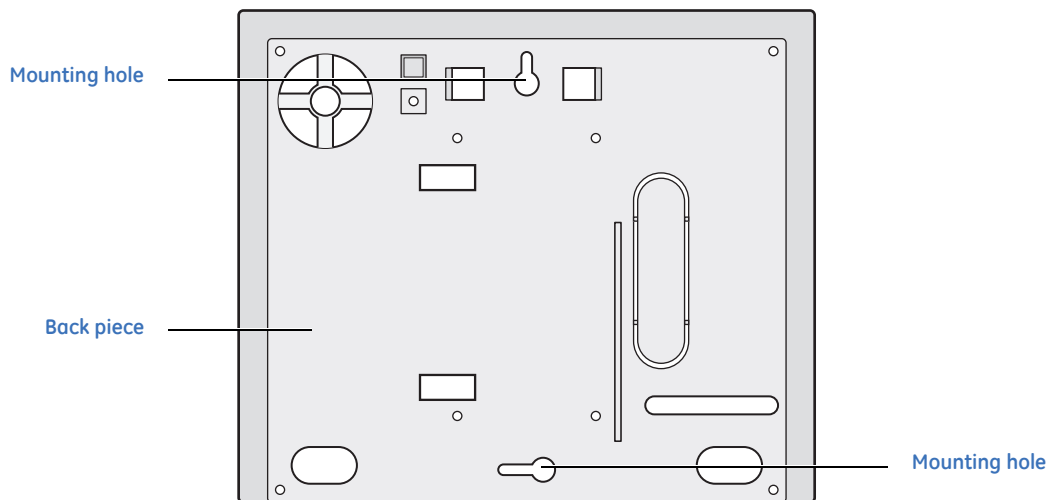

5. Connect the chassis assembly to the mounted back piece and let it hang down. This makes the terminal strip accessible for wiring various hardwired components to the panel.
6. Feed wires through openings in the back piece to be ready to attach them to the screw terminals or the phone connectors.
7. Install all screws and tighten gently.

Connecting hardwired devices

The panel has seven screw terminals and two telephone connections (*Figure 5*). The screw terminals connect AC power, sirens, and/or hardwired detectors.

Program sensors and devices before you install them. Follow the instructions in *Chapter 4 Programming* to add the sensors to panel memory.

Figure 5. Simon XT terminal connections

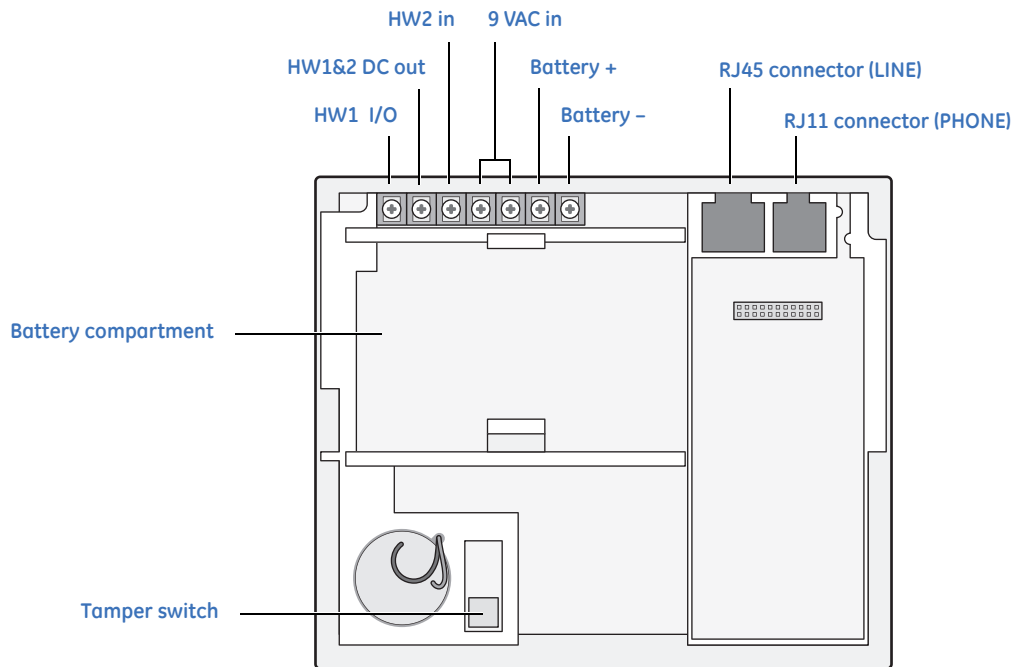

HW1 I/O, HW2 in, and HW1&2 DC out terminals

The *HW1 I/O* terminal is dual purpose and can be used for either siren or hardwired contact connections. The *HW2 in* terminal is an input only.

Interior sirens

From the factory, the *HW1 I/O* input is set up for interior siren operation (status and alarm sounds). *HW1&2 DC out* provides the positive (+) voltage.

Note: The total current available from the *HW1&2 DC out* terminal is 250 mA at up to 122°F (50°C).

With *Hardwired Siren Supervision* turned on, sirens connected to *HW1 I/O* are supervised and require a 4.7 kohm resistor in the circuit. If this terminal is not used, turn *Hardwired Siren Supervision* off.

LD105 hardwired interior siren

Interior sirens must always be wired with a resistor in the circuit. For circuit supervision which allows the panel to detect if the siren wire is cut (open), *Hardwired Siren Supervision* must be turned on. (See *Chapter 4 Programming* on page 29).

Note: Do not install the resistor at the panel terminals. This does not provide supervision of the wire.

Connect the LD105 hardwired interior siren (13-374) to the panel using a 4.7 kohm resistor (included with the siren) as shown in *Figure 6*. The resistor must be connected across the siren wires as close to the siren as possible.

Figure 6. Hardwired interior siren with supervision

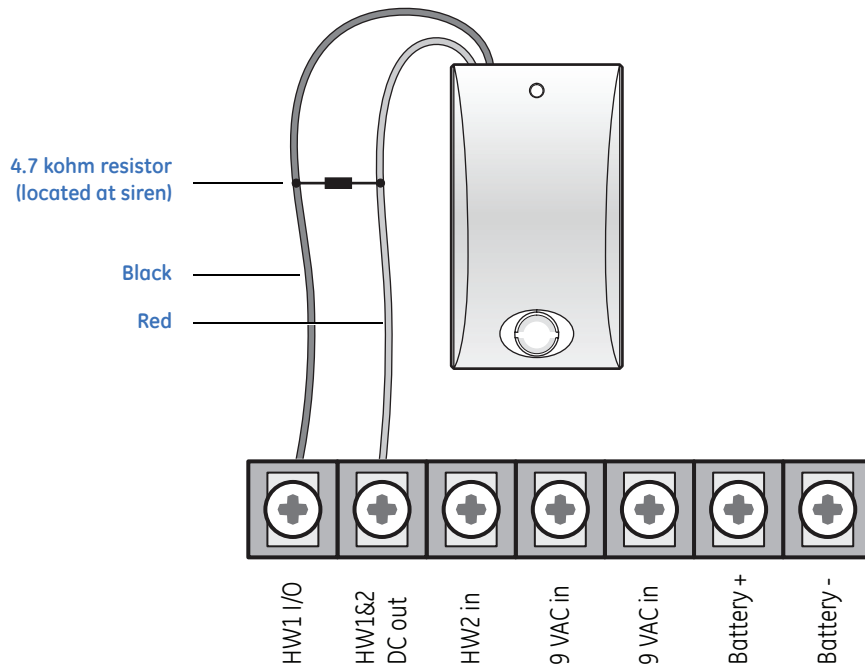

Hardwired contacts

To set up *HW1 I/O* and/or *HW2 in* for hardwired contacts, make the required connections as described under below, then proceed to the *Programming* on page 29 to add (learn) them into panel memory.

You can connect hardwired reed switches (normally closed loop only) to *HW1 I/O* (if not being used for a hardwired siren) and/or *HW2 in*.

Note: Connect only normally closed (NC) reed switches to *HW1 I/O* and/or *HW2 in*. Other types of hardwired detectors should not be used.

The total resistance of the wire loop must not exceed 3 ohms. This allows you to use up to 200 ft. (61 m) of two-conductor, 22-gauge stranded wire.

Connect hardwired reed switches to the panel using a 47 kohm resistor (not a 4.7 kohm resistor) as shown in *Figure 7*. The resistor must be connected at the last switch in the circuit.

Note: Do not install the resistor at the panel terminals. This does not provide supervision of the wire.

Figure 7. Connecting normally closed hardwired reed switches

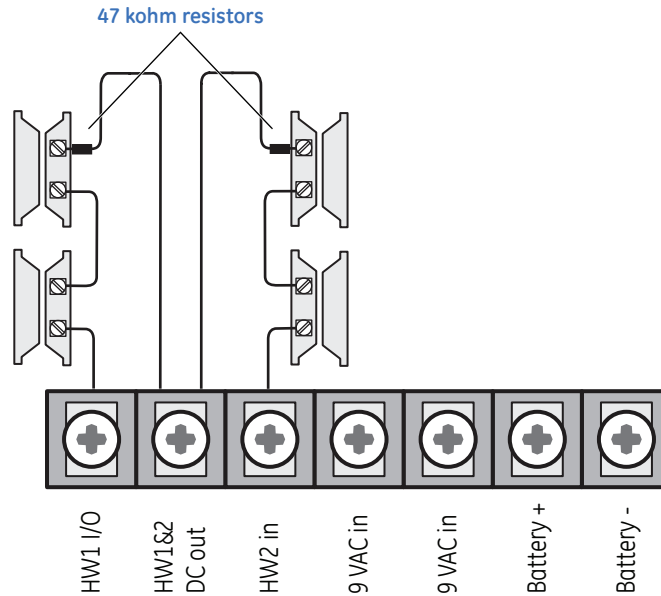

Wiring a phone line to the panel

You can connect a phone line to the panel for systems monitored by a central monitoring station or systems that notify users by a voice event notification.

DSL (digital subscriber line) allows the use of multiple devices on a single phone line simultaneously. For DSL environments, connect the panel line-in jack to an available phone jack on the premises. You might also need an inline filter to ensure panel reporting is successful.

Note: Avoid connecting the panel to a standard phone (voice) line in this manner. Other devices in use at the same time the panel is using the line can prevent reports from going through.

Full line seizure

Full line seizure allows the panel to take over (seize) the phone line, even if another device on the line is in use. This method requires that the panel be wired before all other phones, answering machines, computers, or other devices on the phone line.

Use the RJ31X (CA-38A) jack (*Figure 8* on page 24) when wiring for full line seizure. This lets the user quickly and easily disconnect the panel from the phone line in case the panel disables the phone line due to a malfunction.

Full line seizure wiring with an RJ31X

1. Run a four-conductor cable **A** from the premises Telco block **D** to the RJ31X **B**.
2. Connect the four-conductor cable **A** wires to the RJ31X **B**.
3. Disconnect the green and red premises phone jack wires from the Telco block **D** and splice them **C** to the four-conductor cable **A** black and white (or yellow) wires. Use weatherproof wire connectors for these splices.
4. Connect the four-conductor cable **A** green and red wires to the Telco block **D** TIP (+) and red to RING (-) posts.
5. Connect the phone cord **E** included with the panel to the RJ31X **B** and the panel LINE jack.

Figure 8. Full line seizure wiring with RJ31X

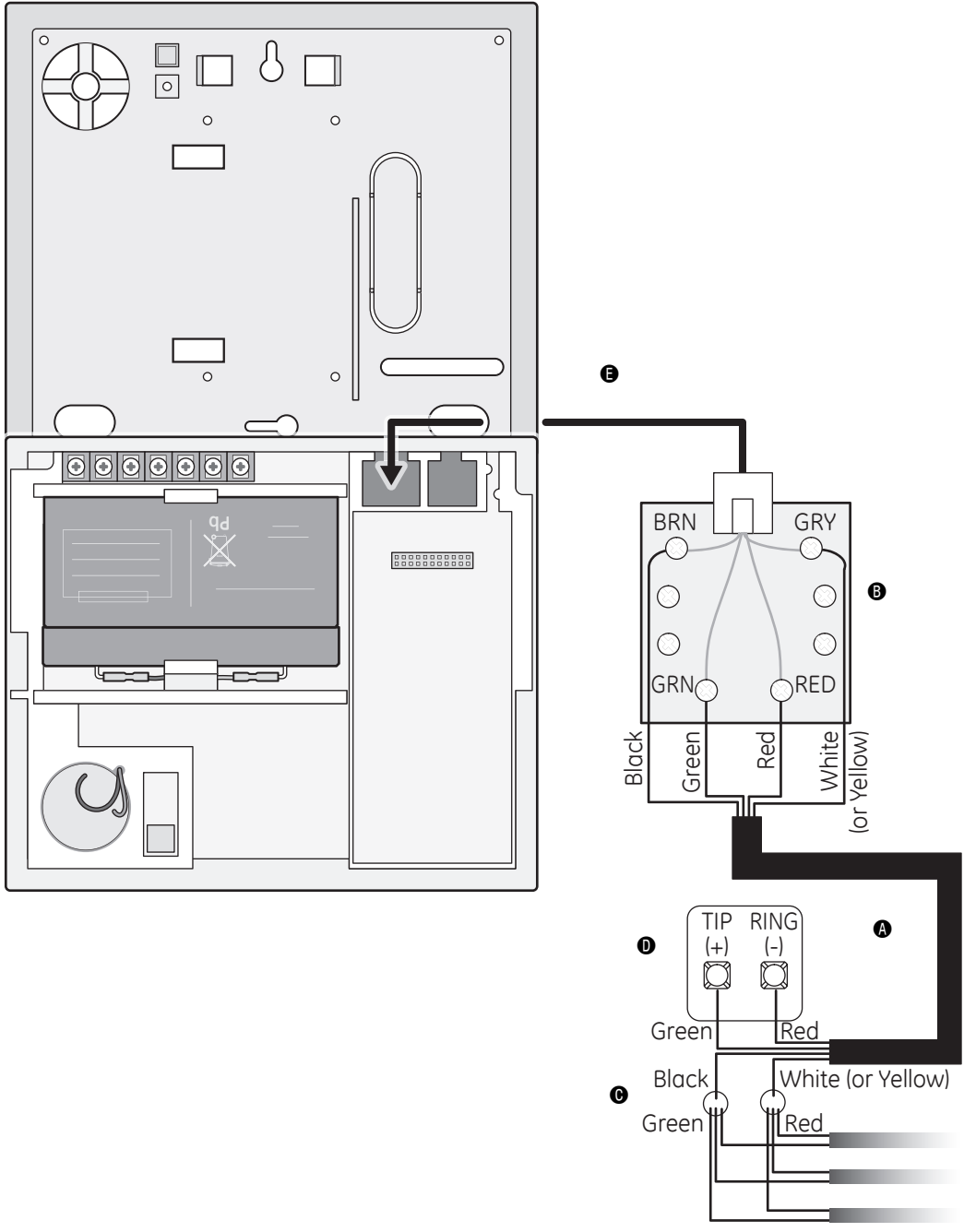

Full line seizure wiring with one premises phone

If a single phone is all that exists on the premises, full line seizure can be accomplished without an RJ31X (Figure 8 on page 25).

1. Disconnect the phone from the premises phone jack and plug it into the panel PHONE jack **A**. This jack is disconnected automatically whenever the panel reports.
2. Connect the included phone cord to the panel LINE jack and the premises phone jack **B**.

Note: If customers add phones or other phone devices to another phone jack, full line seizure no longer exists. Inform them to contact you if they want to add a phone or other device so that you can rewire for full line seizure by adding an RJ31X.

Figure 9. Full line seizure wiring with single landline phone

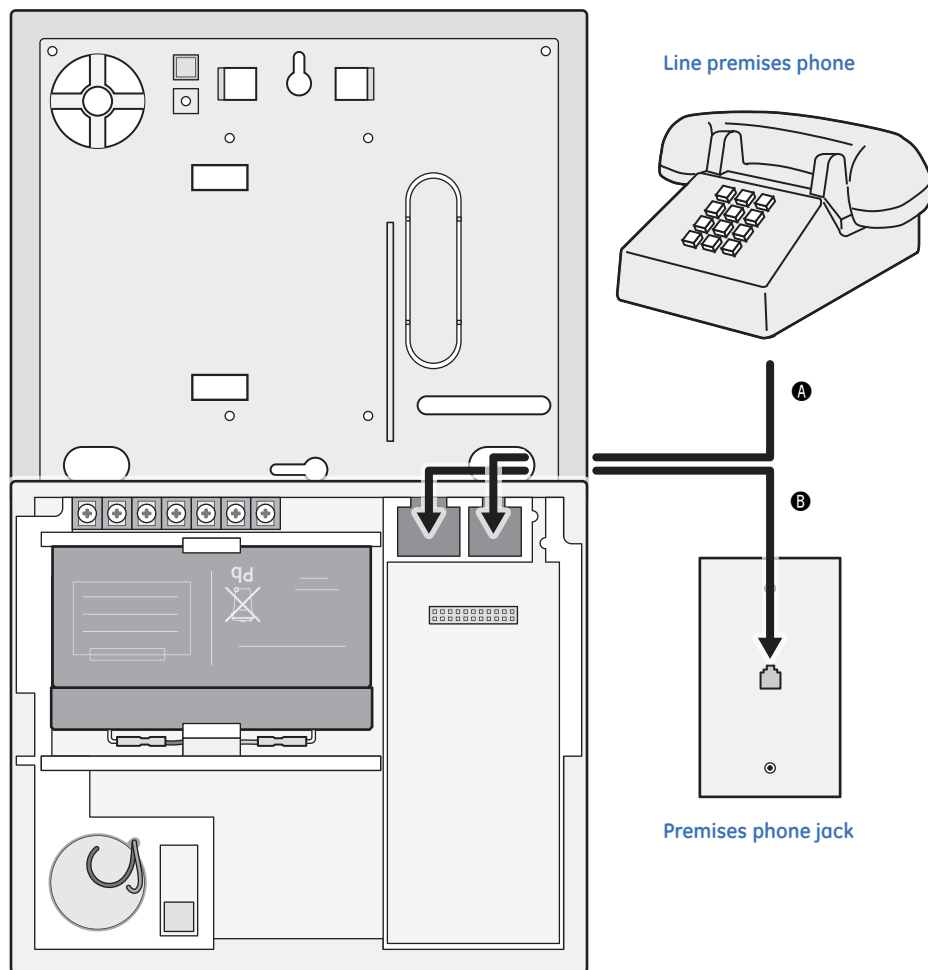

Wiring the power transformer

Connect the power transformer to the panel AC terminals as shown in *Figure 10*.

Figure 10. Transformer connections

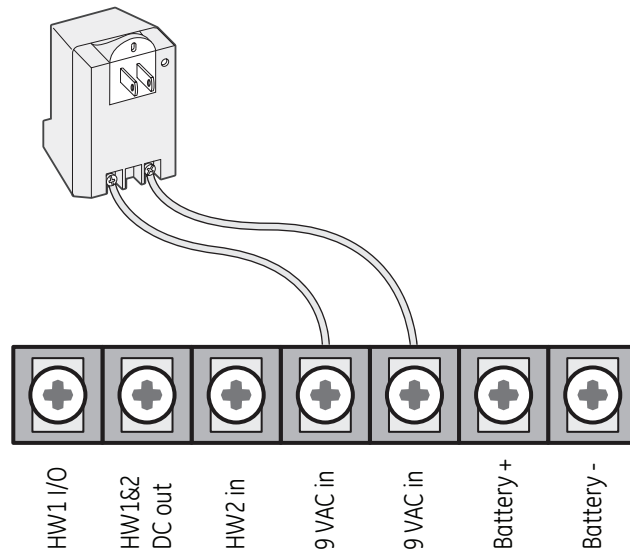

Note: Do not plug in the transformer at this time

Powering up the panel

When applying power to the panel connect the battery first, then plug in the AC power transformer. This sequence prevents a battery fault condition.

Installing the backup battery

To install the backup battery (6 VDC, 1.2 Ah), do the following:

1. Feed the stripped ends (bare stranded wires) of the battery leads underneath the terminal barrier and connect the black wire to the negative (*Batt-neg*) screw terminal and the red wire to the positive (*Batt+pos*) screw terminal (*Figure 11* on page 27).
2. Connect the lug end of the red battery lead to the red battery tab.
3. Connect the lug end of the black battery lead to the black battery tab.
4. Align the red (+) battery terminal with the right end of the terminal strip. The logo and specification information should be readable.
5. Insert the front end of the battery under the forward battery compartment latch.
6. Push forward and rotate the battery downward until it seats beneath the rear battery compartment latch.



CAUTION: Do not connect the battery until you are ready to power up the panel. See [Powering up the panel](#) on page 26.

Figure 11. Installing the panel backup battery

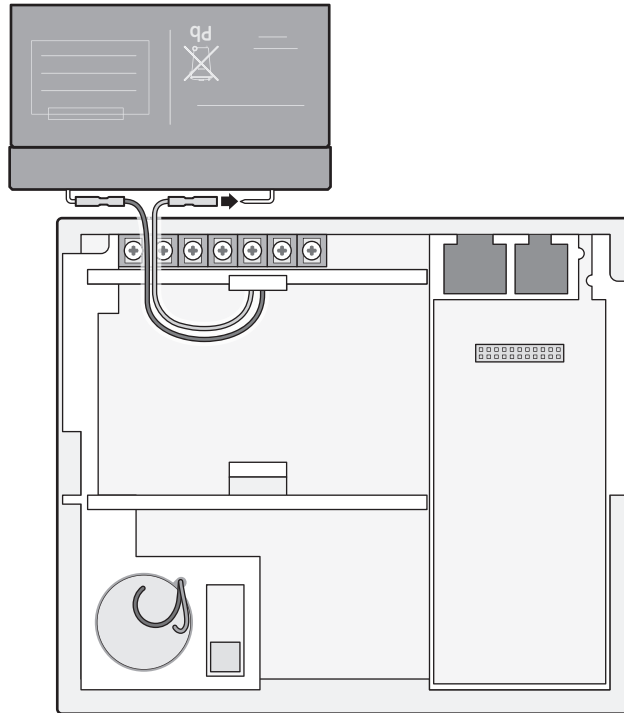

Applying AC power

Make sure the outlet is not controlled by a switch or that it is not part of a ground fault circuit interrupt (GFCI).

1. Remove the center screw from the outlet cover plate and hold the cover plate in place.



WARNING: Use extreme caution when securing the transformer to a metal outlet cover. You could receive a serious shock if a metal outlet cover drops down onto the prongs of the plug.

2. Plug the transformer into the lower receptacle of the outlet so that the hole in the transformer tab lines up with the outlet cover screw hole.
3. Insert the cover plate screw through the transformer tab and the outlet cover plate. Tighten the screw.

Installing X10 modules

To install lamp and appliance modules, do the following:

1. Set the unit code dial to a unit number between 1 and 8.
2. Set the housecode for the installation.
3. Plug the module into a wall outlet.
4. Plug the lamp/appliance into the module.



CAUTION: Do not plug in appliances or lamps with 300-watt or larger bulbs into Lamp Modules

To install universal modules, do the following:

1. Set the unit code dial to a unit number different from all other X10 modules (between 1 and 8).
2. Set the housecode for the installation.
3. Set the module switches to momentary and relay only.
4. Connect the module terminals to the desired device terminals.
5. Plug the universal module into a wall outlet.

Chapter 4 Programming

This chapter provides steps on how to program your unit.

In this chapter:

<i>Programming overview</i>	30
<i>Entering and exiting the system menu</i>	31
<i>Menu navigation</i>	32
<i>Set clock</i>	34
<i>Revision</i>	34
<i>Contrast</i>	34
<i>System programming</i>	35
<i>Access codes</i>	35
<i>Security</i>	36
<i>Phone numbers</i>	37
<i>Phone options</i>	38
<i>Sensors</i>	39
<i>Reporting</i>	41
<i>Timers</i>	44
<i>Touchpad options</i>	45
<i>System options</i>	46
<i>Siren options</i>	47
<i>Piezo beep options</i>	48
<i>Audio verification options</i>	49
<i>Light control (optional)</i>	50
<i>System tests</i>	52
<i>Resetting memory to the factory defaults</i>	53

Programming overview

The control panel *Figure 12* provides the main processing unit for all system functions. The programming of system options and features is menu-driven. All installer options are set in the *System Programming* menu, except for setting the system time. *Table 7* on page 31 explains the panel keys and features shown in *Figure 12*.

Figure 12. Simon XT self-contained panel

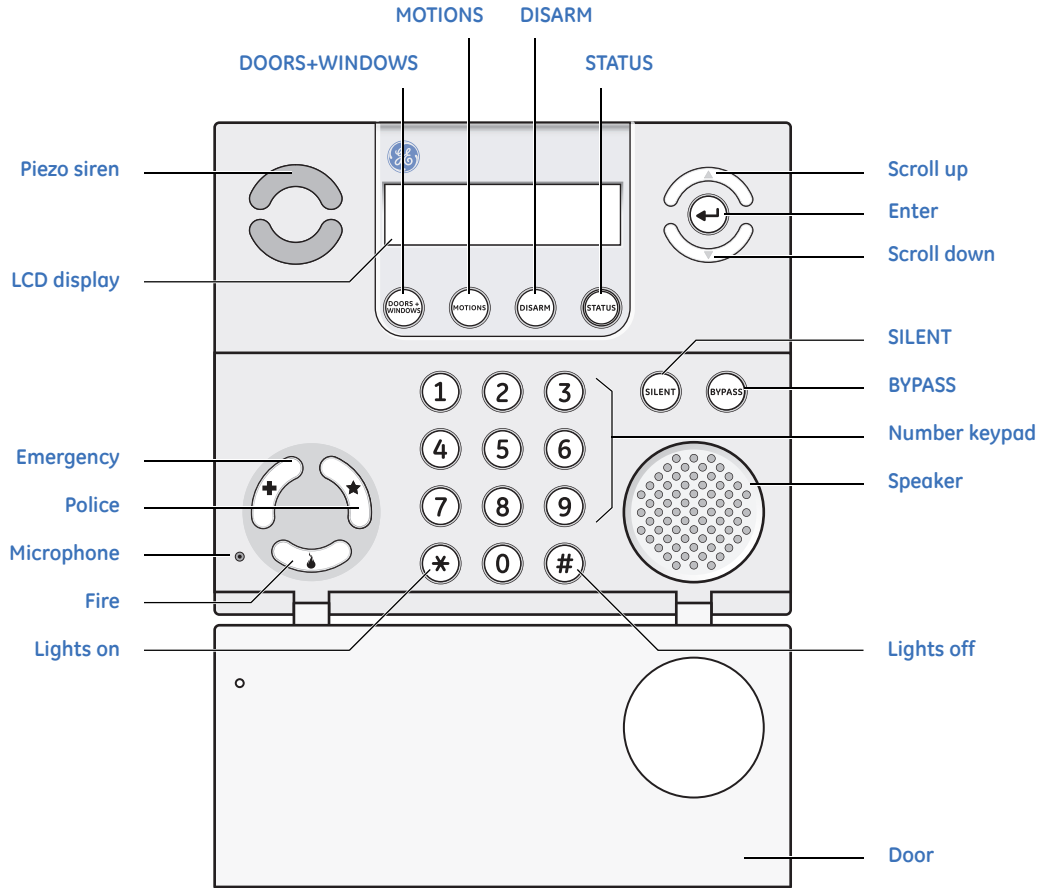





Table 7. Simon XT panel keys and features

Control	Description
Piezo siren	The piezo siren makes alarm beeps and status beeps. Fire and intrusion alarm beeps are always played at high volume, while the volume of status beeps (such as trouble or chime beeps, entry and exit delay beeps, or auxiliary alarm beeps) is programmable.
LCD display	The LCD module has a 2 x 16 character array that displays a variety of phrases and icons.
DOORS + WINDOWS	Press to arm perimeter sensors.
MOTIONS	Press to arm interior sensors.
DISARM	Press to turn off intrusion/burglary protection for your system. Only intrusion/burglary sensors such as doors, windows, and motion sensors are disarmed. Environmental sensors, such as smoke and carbon monoxide, stay active at all times.
STATUS	Press to determine system status.
SILENT	Press to silence exit beeps when arming.
BYPASS	Press to bypass a sensor.
Police 	Press and hold the Police button for two seconds (or press twice quickly) to call the central monitoring station and notify them of a nonmedical call for help.
Emergency 	Press and hold the Emergency button for two seconds (or press twice quickly) to call the central monitoring station and notify them of a nonmedical call for help.
Fire 	Press and hold the Fire button for two seconds (or press twice quickly) to call the central monitoring station and notify them of a nonmedical call for help.
Microphone	Used to communicate with central monitoring station after an alarm.
Scroll up/scroll down	Press to scroll through lists of similar items.
Enter	Press to select a particular menu item or commit to memory a menu item that has just been programmed.
Numeric keypad	Twelve-key telephone-type keypad (0 through 9, *, #) for entering access codes or other numerical data.
Speaker	Provides voice output and sounds key beeps. The panel speaks arming level changes, system status, and voice chime sensor trips. The panel voice is also used for voice reporting and remote phone control.
Door	Covers the lower panel.
*	Lights on.
#	Lights off.

Entering and exiting the system menu

To enter the system menu, press either the scroll up/down or **Enter** buttons in the upper right of the panel.

Press the **STATUS** button to exit a menu or option edit mode and navigate up one level. Pressing the **STATUS** button while in the top menu level exits the system menu level. The panel automatically exits the system menu after a few seconds of inactivity if no access code has been entered yet. After an access code has been entered to access a code-protected area of the system menu, the timeout is 4 minutes.

Table 8. Simon XT menu structure (continued)

Sensors		System options	
	Learn sensor		RF jam detect
	Delete sensor		Demo mode
	Edit sensor		HW1 I/O
Reporting			SIA limits
	Report options		24-hour clock format
	Opening report	Siren options	
	Closing report		Panel piezo beeps
	Force armed report		Panel voice
	AC power failure report		Panel piezo alarms
	Panel low battery report		Trouble beeps
	Sensor alarm restoral report		Voice chime
	24-hour sensor tamper		Status beep volume
	Supervisory/tamper report		Hardwired siren supervision
	No usage report		Speaker volume
	Swinger shutdown		Panel silent police panic
	Programming report		Panel tamper
	Fire alarm verification		Alarm report verification
Communication modes		Audio verification	
	Phone 1 reports		Audio mode
	Phone 2 reports		Fire shutdown
	Phone 3 reports		Panic talk
	Phone 4 reports		VOX receiver gain
Timers			VOX microphone gain
	Latchkey time		VOX gain range
	Entry delay		Manual microphone gain
	Exit delay	Light control	
	No activity timeout		Set entry lights
	Auto phone test		Sensor lights
	Supervisory time		Light schedules
	Alarm cancel window		Housecode
	RF timeout		Lock interval
	Fail to open time	System tests	
	Fail to close time		Sensor test
	Siren timeout		Communication test
	Arming LEDs shutdown		Initiate download call
	Unvacated premises	Revision	
	Smoke sensor supervision	Contrast	
Touchpad options			
	Keyfob no delay		
	Panel panic alarms		
	Remote touchpad arming		

Set clock

If the panel loses both AC and battery power, then upon restoring power the system time will reset to midnight and blink, indicating it has not been set correctly. You can set the system time to display in either 12-hour or 24-hour format.

Time of day format is HH:MMx, where:

HH = 01 to 12 (12-hour format) or 00-23 (24-hour format)

MM = 00 to 59

x = a or p (12-hour format) or none (24-hour format)

To reset the clock:

1. Scroll up/down until the display shows *Set clock*.
2. Press **Enter**.
3. The display shows *Enter Code*.
4. Enter your code with numeric keys. Press **Enter**.
5. Press **Enter**. The display now flashes the hours.
6. Scroll up/down to set the hours.
7. Press the **Enter** key to accept. The display now flashes the minutes.
8. Scroll up/down to set the minutes.
9. Press the **Enter** key to accept. The display is now flashing the AM/PM.
10. Scroll up/down to set the AM/PM.
11. Press **Enter** to accept. The display now shows the current time, and stops flashing.
12. Press the **STATUS** button twice to exit.

Revision

To display the firmware revision of the system:

1. Scroll up/down to *Revision*.
2. Press the **STATUS** button to exit.

Contrast

To adjust the *Contrast* of the display:

1. Scroll up/down to *Contrast*.
2. Press the **Enter** button.
3. Scroll up/down to increase and decrease the contrast setting.
4. Press the **STATUS** button to save the setting and exit.

Note: Changes in contrast are more noticeable when not looking at the display straight-on.

System programming

To enter system programming mode, do the following:

1. Press the scroll buttons until the panel displays *System Programming*.
2. Press **Enter**. The system prompts for an access code.
3. Enter the access code from the codes listed in *Table 9*. The system displays each entered access code digit as an asterisk.
4. Press **Enter**. The panel is now in program mode.

Note: Do not remove panel power while in program mode.

Table 9. Simon XT programming codes

Code	Description
Dealer code	You can use the dealer code to program all system options, including high-security options that are not accessible with the installer code if it is different from the dealer code. Depending on how the access code is set, the default dealer access code is 654321, 54321, 4321 (factory default), or 321. This code can be used for all programming.
Installer code	Depending on how the access code is set, the default installer code is 654321, 54321, 4321 (factory default), or 321. This code is limited to changing all but the following: Dealer code, Code length, Downloader code, Phone lock, Phone #1, Phone #2, Phone 1 report mode, Phone 2 report mode, HW 1 function, SIA limits.

Access codes

Table 10. Access codes

Function	Default	Description
Dealer code	4321	You can use the dealer code to program all system options, including high-security options that are not accessible with the installer code if it is different from the dealer code. Changing the dealer code to differ from the installer code will prevent the installer from viewing certain fields. <ol style="list-style-type: none"> 1. Change the dealer code. 2. Enter program mode with the installer code. 3. Installer should no longer be able to see the following: Code length, Downloader code, Phone lock, Phone #1, Phone #2, Phone 1 report mode, Phone 2 report mode, HW1 function, SIA limits.
Installer code	4321	You can use the installer code to program most installer options, except for high-security dealer options.
Master code	1234	Master arm/disarm code. Master code able to enter user programming and bypass sensors.
User codes 1 to 8	Blank	Regular arm/disarm code.
Duress code	Blank	Use in place of master or user code to cause a silent alarm.
Code length	Four digits	Code can be three to six digits long.

Security

Table 11. Security

Function	Default	Description
Account number	00000	Lets you program up to a 10-character alphanumeric account number or delete an existing account number by pressing DISARM . You can enter numerical digits sequentially. To enter letters (A to F only), use the scroll buttons to select A to F then press Enter . To select next digit, press another number key. When finished press Enter . The CID format only supports account numbers with letters B through F, or numbers 0 through 9 (or a combination of those letters and numbers).
Downloader code	12345	Lets you set a unique five-digit code that is required for initiating Enterprise Downloader sessions. The code must be five digits long and can range from 00000 to 99999. The downloader code must match the downloader access code in the Enterprise account to perform Enterprise sessions.
Phone lock	Off	Prevents resetting of phone/reporting related options when a memory clear is performed (on) or resets these options to their default values when a memory clear is performed (off). The following are not reset when on: <ul style="list-style-type: none"> • Account number • Dealer code • Code length • Call wait cancel • Phone numbers 1 and 2 • Phone report modes 1 to 4 • Phone lock • Downloader phone number • Downloader code
Autoarm	On	Determines how long the system protests (announces open/failed sensors) when attempting to arm with open/failed sensors, before bypassing these sensors and automatically arming the rest of the system. Note: The panel protests an arming attempt when it has not received a restore (close) signal from sensors learned into restore-specific sensors groups. Sensors learned into group 26 (fire) cannot be bypassed. When this option is on, the panel announces all open/failed sensors repeatedly for 4 minutes, then automatically bypasses the open sensors and arms the rest of the system. If a sensor is opened during the exit delay and then left open, the panel will go into alarm after the exit delay has expired. This option must be on for <i>Unvacated premises</i> and <i>Exit extension</i> to work correctly. When this option is off, the panel displays all open/failed sensors once, then automatically bypasses the open sensors and arms the rest of the system after the exit delay has expired. If other sensors are opened during the exit delay, they will also be bypassed if left open. Note: If group 13 (Instant Perimeter) sensors are opened during the exit delay, the panel goes into immediate alarm.

Table 11. Security (continued)

Function	Default	Description
Exit extend	On	Determines whether the panel restarts the exit delay time if the user enters the armed premises during the initial exit delay period (on), or not (off). Turning on this feature allows users to reenter during the exit delay period, without disarming and then rearming the system. Turning off this feature requires the user to disarm and rearm the system. Note: <i>Autoarm</i> must be on for this option to work.
Secure arming	Off	Determines whether an access code is required when arming the system (on) or not (off). This option does not affect keyfob arm/disarm operation.
No arm on low battery	Off	Determines whether the system protests arming if a low CPU battery condition exists (on) or not (off).
Quick exit	Off	Determines whether pressing DISARM when the system is armed activates the exit delay time to allow exit and reentry without disarming the system (on) or not (off). This feature is useful if the user wants to step outside briefly and return, such as to get the paper. If the system is armed and the user presses DISARM , the panel announces <i>Exit time is ON</i> and sounds exit delay beeps. This allows a designated entry/exit door to be open for up to 2 minutes without causing alarm. When the door is closed, the beeps stop and the door is armed again. Note:
Downloader enable	On	Enables programming of system options with downloader software.
Sup protest	Off	Determines whether the panel protests arming if it has not received a supervisory signal from any sensor 15 minutes before arming (on) or not (off). Note: This feature must be turned off for US installations, on for European installations.

Phone numbers

Table 12. Phone numbers

Function	Default	Description
Phone # 1	Blank	Lets you program up to a 26-digit central monitoring station receiver/voice event notification phone number for monitored systems. Phone digits can be 0-9, *, #, or a pause (P). To delete the phone number, press DISARM while editing a phone digit. To add a pause to the phone number press BYPASS . Pressing Enter is required if you enter fewer than 26 digits.
Phone # 2	Blank	
Phone # 3	Blank	
Phone # 4	Blank	
Downloader #	Blank	Lets you program up to a 26-digit phone number for the Enterprise Downloader.

Phone options

Table 13. Phone options

Function	Default	Description
Man phone test	On	Determines whether the user can perform a manual communication test to verify communication to a central station/voice dial (on), or not (off). If you have all 4 phone # programmed it should send a test report to all 4 before showing that test is okay.
FTC	On	Determines whether the panel and interior sirens sound trouble beeps if it is unable to successfully send a report to a central station (on) or not (off).
DTMF dial	On	Determines whether the panel uses DTMF (on) or pulse (off) for dialing programmed phone numbers.
300 bps enabled	On	Determines whether the baud rate used by the panel for central station communication is 300 bps (on) or 110 bps (off).
Ring hang ring	1	<p>Determines when the panel answers a remote phone access or Enterprise call. Depending on whether an answering machine exists at the panel location, offsite access to the panel can be done with a series of phone calls or just one. For offsite access where an answering machine does not exist, the user or Enterprise operator simply calls the panel location once and listens for 10 rings. The panel should answer after the tenth ring.</p> <p>For offsite access where an answering machine exists, the user or Enterprise operator must perform the following steps:</p> <ul style="list-style-type: none"> • Call the panel location. • Let the phone ring once, then hang up. • Wait at least 10 seconds but not more than 40, then call the panel location again. The panel should answer on the first ring. <p>Ring/hang/ring setting number and sequence of rings after which the panel answers:</p> <ol style="list-style-type: none"> 1 Ring/hang/ring or ten rings 2 Ring/hang/ring/hang/ring or ten rings 3 Ring/hang/ring/hang/ring/hang/ring or ten rings 4 Ten rings 5 Ring/hang/ring 6 Ring/hang/ring/hang/ring 7 Ring/hang/ring/hang/ring/hang/ring <p>Off Disabled—no remote (offsite) access</p>
Dial delay	30 seconds	<p>Determines whether the panel delays dialing programmed phone numbers before sending reports (on).</p> <p>If Opening (Disarming) Reports is on, the panel does not delay dialing if the system is disarmed before the delay time expires. The panel dials immediately for both the alarm and opening report.</p> <p>Note: Regardless of this option setting, the panel always dials immediately for fire alarms, AC power failure and low battery reports.</p> <p>The delay time can be set from 5 to 254 seconds (15 to 45 if SIA Limits option is on).</p>

Table 13. Phone options (continued)

Function	Default	Description
Call wait code	Off	<p>The call waiting code is dialed by the panel before a phone number to disable call waiting. Verify that the end-user has call waiting with his phone service provider before changing this option from its default.</p> <p> CAUTION: Changing this option from its default without call waiting will prohibit the panel from calling the central station.</p> <p>The call waiting code is programmed the same way as a phone number.</p>

Sensors

These instructions tell how to add (learn) sensors, touchpads, and other system devices into panel memory. The panel recognizes a sensor when you press a sensor program button, press and release a tamper switch, press a sensor test button, or put a sensor into alarm. *Table 14* describes the programming method for each device.

Note: If you are installing a sensor on a gun case, jewelry box, or a similar case, and the sensor is active in level one, you must subdisarm to avoid putting the panel into alarm when the sensor and the magnet are separated.

Table 14. Device programming

Device	To program
Door/window sensor	Press the button on the top of the sensor (cover removed) or trip the tamper.
Motion sensor	Press the button on the back of the sensor (mounting plate removed) or trip the tamper.
Smoke detector	Trip the tamper, press the test button, remove the detector from its base, or put the smoke detector in alarm.
Hardwired sensor	Separate the sensor from its magnet.
CO alarm	Plug in the module wait 5 to 7 seconds press and hold the test button for nine beeps
Freeze and water sensor	Trip the tamper or press and hold the button on the top of the sensor (cover removed) until the control panel confirms programming. If you do not hold the button down long enough, the system will report the sensor as open.
Personal help button	Press the help button until the light blinks.
Remote handheld touchpad	Press the emergency buttons.
Keyfob	Press the lock and unlock buttons at the same time.
ELM keyfob	<p>Do the following:</p> <ol style="list-style-type: none"> 1. Press the unlock button twice and hold it the third time. The light button flashes three times. 2. Press the unlock button once and hold it the second time. The light button flashes twice. 3. Press and hold the unlock button. The light button flashes once. Hold the button until the flashing stops.

When learning sensors, the panel uses an ascending number sequence starting with 1. You can override this by entering the desired sensor number using the number keys.

Learning sensors

To learn a sensor:

1. Press the scroll buttons until the panel displays *System programming*.
2. Press **Enter**. The system prompts for an access code.
3. Enter the dealer or installer code and press **Enter**. The panel displays *Access Codes*.
4. Press the scroll buttons until the panel displays *Sensors*.
5. Press **Enter**. The panel displays *Learn sensor*.
6. Press **Enter**. The panel displays *Trip sensor ##*, with the number signs flashing.

Note: If you wish to use a sensor number other than the next one available, use the number keys to enter a two-digit sensor number immediately.

7. Press the sensor program button or release the sensor tamper switch. The panel displays *Sn ## Grp 10 <Front Door>*, with the *Grp 10* flashing. Use the number or scroll buttons if you want to enter a new group number; press **Enter** to accept the group number displayed.
8. The sensor text is now flashing. Use the scroll buttons to scroll through the text list or enter the three-digit shortcut. (See *Table 36* on page 68 and *Table 37* on page 69 for these three-digit codes). Press **Enter** to accept the first text segment. You may enter more text or press **Enter** again to finish adding the sensor.
9. The panel displays *Trip Sensor ##* (with the next available sensor number). Press **STATUS** repeatedly to exit.

Deleting sensors

To delete a sensor:

1. Press the scroll buttons until the panel displays *System programming*.
2. Press **Enter**. The panel displays *Enter Code*.
3. Enter your access code and press **Enter**. The panel displays *Access Codes*.
4. Press the scroll buttons until the panel displays *Sensors*.
5. Press **Enter**. The panel displays *Learn sensor*.
6. Press the scroll buttons until the panel displays *Delete Sensor*.
7. Press **Enter**. The panel displays *Sn ## Grp ## <Text>*.
8. Press the scroll buttons until the panel displays the sensor you want to delete.
9. Press **Enter**. The panel displays *Deleted*, then shows *Delete Sensor*.
10. Press **STATUS** twice to exit.

Editing sensors

You can use this feature to change the group or name of a sensor that is already in panel memory. The procedure is very similar to the procedure used to program sensor information after a sensor is learned in. Pressing **DISARM** while editing sensor text deletes all text for that sensor.

Table 15. Sensors

Function	Default	Description
Learn sensors		Adds (learns) sensors to panel memory.
Delete sensors		Deletes sensors from panel memory.
Edit sensors		Edits sensor information in panel memory.

Reporting

Table 16 and Table 17 on page 43 provide report option details.

Table 16. Reporting options

Function	Default	Description
Opening reports	Off	<p>Determines whether the panel sends opening reports to a central station whenever the system is disarmed (on), or not (off). User number will be reported as zone number.</p> <p>Keyfobs learned into zone 1 to 40 will report as zone they are learned into.</p> <p>Dealer code = 44</p> <p>Installer code = 45</p> <p>Master code = 46</p> <p>User code 1 = 47</p> <p>User code 2 = 48</p> <p>User code 3 = 49</p> <p>User code 4 = 50</p> <p>User code 5 = 51</p> <p>User code 6 = 52</p> <p>User code 7 = 53</p> <p>User code 8 = 54</p> <p>Duress code = 55</p>

Table 16. Reporting options (continued)

Function	Default	Description
Closing reports	Off	Determines whether the panel sends closing reports to a central station whenever the system is armed (on), or not (off). User number will be reported as zone number. Keyfobs learned into zones 1 through 40 will report as the zone they are learned into. Dealer code = 44 Installer code = 45 Master code = 46 User code 1 = 47 User code 2 = 48 User code 3 = 49 User code 4 = 50 User code 5 = 51 User code 6 = 52 User code 7 = 53 User code 8 = 54 Duress code = 55
Force armed	Off	Determines whether the panel sends a force armed report to a central station if the user bypasses protesting sensors (indirect bypass) when arming the system (on) or not (off).
AC power failure	Off	Determines whether or not the panel sends AC power failure reports to a central station after the programmed time expires. The time can be set from 005-254 minutes. <ul style="list-style-type: none"> When the panel is without AC power for 30 seconds, the panel LEDs turn off. When the panel is without AC power for the programmed time, an AC power failure is reported. The panel reports an AC power restoral when AC power returns to the panel.
Low CPU battery	On	Determines whether the panel sends a low CPU battery report to the central station when the panel backup battery voltage drops
Sen alarm restore	Off	Determines whether the panel reports sensor alarm restorals (on) or not (off). Setting when restorals are reported: <ol style="list-style-type: none"> Immediately after sensor is closed or restored after dial delay. After siren timeout expires if sensor is restored. When system is disarmed if sensor is restored.
24-hour sensor tamper	Off	Determines whether the system (armed or disarmed) goes into and reports an alarm anytime a sensor tamper switch is tripped (on), or only when the system is armed and a tamper switch of an armed sensor is tripped (off).
Supervisory tamper	Off	Determines whether the panel sends supervisory reports to a central station as a tamper (on) or a supervisory (off). This option is typically used only in Europe where a supervisory condition is required to report as a tamper.
No usage	Off	Determines whether the panel sends a No Usage report to the central station if the user has not operated the system before the programmed time expires (on) or not (off). The timer starts each time the system is disarmed. This is a customer service feature that alerts the central station if a customer is not using their security system. The service provider can then contact the customer to find out why the system is not being used, and help correct any problems for the customer.

Table 16. Reporting options (continued)

Function	Default	Description
Swinger shutdown	On	Determines whether the panel prevents the same sensor from activating an alarm more than once in a single arming period (on) or not (off). Note: Swinger Shutdown does not affect smoke and fire sensors.
Program report	Off	Determines whether the panel sends a report to the central station anytime the programming mode is entered/exited (on) or not at all (off). The panel sends a report whenever the dealer (Utility 1) or installer (Utility 2) code is used to enter programming mode and another report is sent when the programming session ends.
Fire verify	Off	Determines when a fire alarm is reported to the central station. If this option is on, a single smoke sensor must stay in alarm for at least one minute before the panel reports the alarm to the central station. If a second (different) smoke sensor goes into alarm before the Siren Timeout expires, the panel immediately reports the alarm to the central station. If this option is off, the panel immediately reports an alarm to the central station when a smoke sensor goes into alarm.

Table 17. Communication modes

Function	Default	Description
Phone 1 report mode	Off	All SIA All CID
Phone 2 report mode		Alarm SIA Alarm CID
Phone 3 report mode		Nonalarm SIA Nonalarm CID
Phone 4 report mode		Backup SIA (phone failure backup) Backup CID (phone failure backup) Voice dialer Off

Alarms include: Fire, Intrusion, Emergency, Silent, and Alarm Cancels.

Nonalarms include: Latchkey, No Activity, Openings, Closings, Fail to Open, Fail to Close, Force Armed, AC Power Failure, CPU Low Battery, and Trouble Restorals.

Timers

Table 18 provides timer option details.

Table 18. Timers

Function	Default	Description
Latchkey time	Off	Determines whether the panel reports a latchkey alarm if the system is not disarmed at a preset time between midnight and 11:59 P.M. (on). If the latchkey feature is disabled (off), the panel will not report a latchkey alarm. The system clock must be set for the latchkey feature to work.
Entry delay	030 seconds	Determines how much time the user has to disarm the system after entering the armed premises through a designated delay door, before an alarm occurs. Beeps sound during the entire delay time to remind the user to disarm the system. When turned on, the Entry Delay can be set from 005 to 240 seconds (030 to 240 seconds if SIA limits option is on).
Exit delay	060 seconds	Determines how much time the user has to leave the premises through a designated delay door after arming the system. Beeps sound after arming the system to remind the user to leave the armed premises. If a delay door is opened after the Exit Delay expires, the Entry Delay begins. If the user arms the system with No Delay and opens a delay door after the Exit Delay expires, an alarm occurs. When turned on, the Exit Delay can be set from 005 to 254 seconds (045 to 254 seconds if SIA limits option is on).
No activity tm	Off	Determines whether the panel sends a No Activity report to a central station when the programmed time period elapses (on), or if the feature is disabled (off). No activity means control panel, remote handheld, and key-chain touchpad buttons have not been pressed and sensors have not been tripped within a specified period of time (except sensors in group 25). The timeout can be set from 02 to 24 hours.
Auto phone test	Off	Determines whether the panel automatically performs a periodic phone test (on) or not (off). The test interval can be from 001 to 254 days. The time of day the panel performs the test is determined by Supervisory Time, which must be turned on for this feature to work.
Supervisory time	12:00am	Determines when the panel reports supervisory conditions (sensor failures) and automatic phone tests to the central station. The panel clock must be set to the correct time for this option and the automatic phone test to work correctly.
Alarm cancel	006	Sets the time frame that determines whether the panel reports an alarm cancel message to the central station. If the system is disarmed from an alarm state within the programmed time, the panel sends an alarm cancel message to the central station. An alarm cancel message is not reported if the system is disarmed after the programmed time expires. The time can be set from 006 to 255 minutes. When set to 255, the panel always reports alarm cancel messages. Turning off this option disables alarm cancel reporting.
RF time-out	12 hours	Determines the time period the panel must receive at least one supervisory signal from learned sensors before identifying a sensor failure and sounding trouble beeps. Any sensor failure is reported immediately and again at the supervisory time (Supervisory Time). The timeout can be set from 02-36 hours. Entries must be two digits.

Table 18. Timers (continued)

Function	Default	Description
Fail-to-open time	Off	Determines whether the panel sends a <i>Fail to open</i> report to a central station if the system has not been disarmed by the programmed time (on), or not (off). System time must be set correctly for this feature to work.
Fail-to-close time	Off	Determines whether the panel sends a Fail to Close report to a central station if the system has not been armed by the programmed time (on), or not (off). System time must be set correctly for this feature to work.
Siren time-out	004 minutes	Determines how long sirens sound alarms if no one is present to disarm the system. The time can be set from 002 to 254 minutes. When this feature is turned off, sirens sound alarms until the alarm is canceled (system is disarmed).
Arm LED shutdown	Off	Determines whether the panel LEDs (buttons) turn off 30 seconds after the last button press (on) or remain on for the entire arming period (off).
Unvacated premises	On	Determines whether the system automatically arms down to level 2 (doors and windows) if the user arms the system to level 4 (doors, windows, and motion sensors) without leaving the premises (on), or remains at the armed level chosen by the user (off). This feature does not work from a keyfob. Autobypass must be on for this feature to work.
Smoke supervision	Off	Determines how often the panel must receive supervisory signals from the smoke sensors. If this option is on, the panel must receive at least one supervisory signal from smoke sensors every four hours or it will identify a sensor failure and sound trouble beeps. If this option is off, the time for receiving supervisory signals is determined by RF Timeout.

Touchpad options

Table 19 provides touchpad option details.

Table 19. Touchpad options

Function	Default	Description
Keyfob no delay	Off	Determines whether a keyfob arms the system with no delay (on) or not (off). When this feature is on, you must disarm the system before entering the premises, since it is disabling the entry delay. If <i>Remote Touchpad Arming</i> is on, keyfobs cannot disarm the system and will cause an alarm upon entering.
Panic alarms	On	Determines whether the panel panic buttons (police, auxiliary, and fire) activate alarms when pressed (on) or not (off)
Remote TP arm	Off	Determines whether keyfobs and remote touchpads can disarm the system only during exit and entry delays (on) or arm and disarm the system anytime (off). If this option and <i>Keyfob no delay</i> are on, users cannot enter and/or disarm using remote touchpads without causing an alarm.

System options

Table 20 provides system option details.

Table 20. System options

Function	Default	Description
RF jam detect	Off	Determines whether the panel checks for and reports RF interference/jam to the central station (on) or not (off). If this option is on and the panel receives a constant 319.5 MHz signal, the panel reports the condition to the central station. If this option is off, the panel does not detect an RF jam.
Demo mode	Off	Determines whether the panel operates as a demonstration model (on) or a standard panel (off). Turning on this feature disables low battery supervision and allows the microphone to remain on continuously during an AVM session. With option on panel is not testing battery supervision.
HW 1 function	1	The setting for this option determines how the HW1 I/O output will function. Off = No output. 1 = Interior siren output. 2 = Output activated when armed. 3 = Output activated when disarmed. 4 = Fail to communicate output; activates when fail to communicate condition occurs (Fail to communicate must be on) two. 5 = Alarm output activated when panel is in alarm
SIA limits	On	Determines whether entry, exit, and dialer delay times fall within SIA limits (on) or factory ranges (off). Entry Delay 030 to 240 seconds 005 to 240 seconds Exit Delay 045 to 254 seconds 005 to 254 seconds Dialer Delay 015 to 045 seconds 005 to 254 seconds
24-hour clock	Off	Determines whether the panel uses a 24-hour clock (on) or 12-hour clock (off).

Siren options

Table 21 provides siren option details.

Table 21. Siren options

Function	Default	Description
Piezo beeps	On	This option determines whether the panel piezo produces beeps based on system activity (on) or is silent (off).
Panel voice	On	When On, arming level changes will be spoken.
Panel piezo alarm	On	Determines whether the panel piezo emits alarm sounds (on) or not (off).
Trouble beeps	On	Determines whether the panel, X10, and hardwired interior sirens sound six beeps every minute when a trouble condition occurs (on) or not (off). The following conditions cause trouble beeps: AC power failure (when AC power failure report is on) low CPU battery Sensor failure (supervisory) Sensor trouble (low battery, tamper, etc.) Fail to communicate Restoration of power No Activity timer has timed out. Trouble beeps continue for 5 minutes and if the panel does not see activity, trouble beeps stop and the panel reports the no activity to the central station. Trouble beeps can be silenced by arming or disarming the system or by pressing the STATUS button. Trouble beeps resume 4 hours later if the trouble condition is not cleared.
Voice chime	Off	Determines whether the panel announces the sensor name. 1 = Sensor name 2 = Loud ding-dong bell 3 = Soft ding-dong bell Off = No sound
Status beeps vol.	7	Determines the panel piezo volume level for status sounds such as arming, trouble, and status beeps. Volume range is 1 (lowest) to 10 (highest).
HW siren sup.	Off	Determines whether the panel monitors hardwired sirens for open conditions (on) or not (off). If this option is turned on, sirens connected to the panel terminals require an EOL resistor in the wire circuit. (See Chapter 3 Installing the system on page 17 for siren wiring.) If this option is turned off, EOL resistors are not required whether sirens are connected or not.
Speaker volume	8	Sets the volume of voice messages from the panel speaker. Volume range is 1 (lowest) to 8 (highest).
Silent police panic	Off	Determines whether pressing the panel police panic button causes an audible (off) or silent (on) alarm.
Panel tamper alarm	Off	Determines whether the panel activates a tamper alarm anytime the cover is opened (On) or only when the system is armed (Off).
Alarm report verify	Off	This option determines whether the panel verifies successful alarm reports to the central station by displaying <i>Phone comm is OK</i> (On), or not (Off).

Piezo beep options

Table 22 provides piezo beep option details

Table 22. Panel piezo beeps

Activity	Piezo beep response
Arm doors and windows	Exit delay—two beeps sound every five seconds and two times per second during the last ten seconds. Silent exit—two beeps sound at the beginning of the exit delay and two more sound just before the exit delay expires. Entry delay—two beeps sound every five seconds and two times per second during the last ten seconds.
Arm motion sensors	Exit delay— three beeps sound every five seconds and three times per second during the last ten seconds. Silent exit— three beeps sound at the beginning of the exit delay and three more sound just before the exit delay expires. Entry delay— three beeps sound every five seconds and three times per second during the last ten seconds.
Arm doors/ windows and motion sensors	Exit delay— four beeps sound every five seconds and four times per second during the last ten seconds. Silent exit— four beeps sound at the beginning of the exit delay and four more sound just before the exit delay expires. Entry delay— four beeps sound every five seconds and four times per second during the last ten seconds.
Disarm	One beep
Chime	Two beeps (when programmed)
Special chime	Three beeps (when programmed)
Trouble beeps	Six beeps every minute. Press STATUS to stop beeps for four hours.
No activity	Twenty beeps every minute for five minutes (when programmed)

Audio verification options

Table 23 provides audio verification option details.

Table 23. Audio verification

Function	Default	Description
Audio mode	Off	1 = Instant. Panel stays online with central station for an instant audio session. 2 = Callback. Panel hangs up and waits for a callback from the central station operator before starting an audio session. Off = No audio verification.
Fire shutdown	Off	Determines whether system Fire sirens are silenced during a two-way audio session (on) or not (off). Beeps sound every 10 seconds while sirens are silenced.
Panic talk	Off	Determines whether the central station operator can talk to the user during a silent alarm (off) or just listen in on the premises (on). Silent alarms occur when sensors learned into groups 02 or 03 are tripped, when the duress code is entered, or when the panel Police button is pressed and the Silent Panel Police Panic option is turned on.
Vox Rx gain	06	Determines the receiver gain level during two-way audio sessions. If the VOX is switching the speaker on when the central station operator is not talking, lower both this setting and the VOX mic gain setting. If the VOX is not switching the speaker on when the central station operator is talking, raise this setting and lower VOX Mic Gain setting. Changing this setting does not affect speaker volume.
Vox mic gain	24	Sets the mic gain (sensitivity) that triggers the voice-activated switching (VOX). Room size, acoustics, and furnishings where the panel or Interrogator 200 are located will influence the setting. Gain range is 01 (lowest) to 64 (highest).
Vox mic gain rng	64	Sets the gain range for voice-activated switching (Vox). Range is 01 (lowest) to 64 (highest). For best results, this option should be set equal to or greater than Vox mic gain. Note: This option works in conjunction with Vox mic gain. It is important to follow the setting recommendations as described to achieve acceptable operation.
Manual mic gain	64	Determines the gain level (sensitivity) during two-way audio sessions when audio mode is set to 0 or 1 (speak). Room size, acoustics, and furnishings where the panel is located will influence the setting. Gain range is 01 (lowest) to 64 (highest).

Light control (optional)

If your system uses optional X10 modules, you can program them to control lights.

X10 module operation

Use the following procedure to program X10 module operations into panel memory.

To program the housecode:

1. Press the scroll buttons until the panel displays *System Programming*.
2. Press **Enter**. The panel displays *Enter Code*.
3. Enter your access code and press **Enter**. The panel displays *Access Codes*.
4. Press the scroll buttons until the panel displays *Light Control*.
5. Press **Enter**. The panel displays *Set Entry Lights*.
6. Press the scroll buttons until the panel displays *Housecode <A-O>*.
7. Press **Enter**. The letter flashes.
8. Press the scroll buttons until the letter you want displays.
9. Press **Enter** to accept the new housecode. The panel displays *Housecode <new housecode>*.
10. Press **STATUS** twice to exit program mode.

To program an entry-activated light:

1. Press the scroll buttons until the panel displays *System Programming*.
2. Press **Enter**. The panel displays *Enter Code*.
3. Enter your access code and press **Enter**. The panel displays *Access Codes*.
4. Press the scroll buttons until the panel displays *Light Control*.
5. Press **Enter**. The panel displays *Set Entry Lights*.
6. Press **Enter**. The panel displays *Entry Light Unit 1 On/Off*.
7. Press the scroll buttons until the unit number you want to program displays.
8. Press **Enter**. The panel displays *Off*, which will be flashing.
9. Press the scroll buttons until the panel displays *On*, then press **Enter**.
10. Press **STATUS** three times to exit program mode.

To program a sensor-activated light:

1. Press the scroll buttons until the panel displays *System Programming*.
2. Press **Enter**. The panel displays *Enter Code*.
3. Enter your access code and press **Enter**. The panel displays *Access Codes*.
4. Press the scroll buttons until the panel displays *Light Control*.
5. Press **Enter**. The panel displays *Set Entry Lights*.

6. Press the scroll buttons until the panel displays *Sensor Light*.
7. Press **Enter**. The panel displays *Sn ## <Text> X-10 unit = On/Off*.
8. Press the scroll buttons until the panel displays the sensor number you want to activate.
9. Press **Enter**. The panel displays *On/Off*, which will be flashing.
10. Press the scroll buttons until the panel displays *On*.
11. Press **Enter**.
12. Press **STATUS** three times to exit.

Note: You can also program a keyfob button to control a light or appliance module.

To program a light schedule:

1. Press the scroll buttons until the panel displays *System Programming*.
2. Press **Enter**. The panel displays *Enter Code*.
3. Enter your access code and press **Enter**. The panel displays *Access Codes*.
4. Press the scroll buttons until the panel displays *Light Control*.
5. Press **Enter**. The panel displays *Set Entry Lights*.
6. Press the scroll buttons until the panel displays *Set Entry Lights*.
7. Press **Enter**.
8. Press the scroll buttons until the panel displays *Light Schedules*.
9. Press **Enter**. The panel displays *Light Schedule 1 <--:-- - -:-->*.
10. Press the scroll buttons until the panel displays the unit number you want to program.
11. Press **Enter**. The *HH* of the start time will flash.
12. Press the scroll buttons to set the hours.
13. Press **Enter**. The *MM* of the start time will flash.
14. Press the scroll buttons to set the minutes.
15. Press **Enter**. The *AM/PM* of the start time will flash.
16. Press the scroll buttons to set the AM/PM setting.
17. Press **Enter**. The end time starts to flash.
18. Follow the same instructions to set the hour, minute, and AM/PM settings for the end time.
19. Press **STATUS** repeatedly to exit.

Lock interval

Sets the start and stop times that determine when the panel prevents the sensor-activated lights feature from turning on sensor-activated lights.

Note: System time must be set correctly for this feature to work.

When a time value is set (on) and the sensor-activated lights feature is on, the panel prevents sensor-activated lights from turning on between the programmed start time (this option) and the programmed stop time.

Note: Both sensor-activated light lockout start time and sensor-activated light lockout stop time must have a time programmed for this feature to work correctly.

When both sensor-activated light lockout start time and sensor-activated light lockout stop time are turned off and the sensor-activated lights feature is on, sensor-activated lights turn on at all times.

Table 24. Light control

Function		Default	Description
Set entry lights:	Entry light unit, 1 through 8	Off	This menu allows the user to set X-10 lights with unit numbers from 1 to 8 as entry lights (On).
Sensor light # 01 to 40			In this menu, each enrolled sensor can be associated with an X-10 light with unit number from 1 to 8 (or Off for no association).
Light schedules	Light schedule, 1 through 8	Off	In this menu, a light schedule can be programmed for each X-10 module with unit number from 1 to 8.
Housecode		A	
Lock interval	(Light) lock interval	Blank	This option sets the daily lockout time during which sensor trips do not activate associated X-10 lights

System tests

Table 25. System tests

Function		Default	Description
System tests	Sensor test		The communication test is used to check the phone communication between the panel and the central station or voice report destination.
	Comm test		The sensor test is used to check proper sensor operation.
	System download		This feature initiates a phone call from the panel to the Enterprise Downloader.

Resetting memory to the factory defaults

To reset the panel to its factory defaults, do the following:

1. Open the panel cover.
2. Unplug the transformer and disconnect the battery.
3. Press and hold the four arming/status buttons (**DOORS+WINDOWS**, **MOTIONS**, **DISARM**, and **STATUS**) on the front of the panel and the tamper switch on the inside of the panel (see *Figure 5* on page 20).
4. Restore power to the panel with the battery while holding the four buttons and tamper switch.
5. Release the buttons.
6. Plug in the transformer to the outlet.

Note: The procedure to reset memory to factory defaults is meant to be difficult. It is also possible to restore power to the panel by plugging in the transformer first, which allows the panel to be closed so that the tamper switch does not need to be pressed. If you do this, be sure to reconnect the battery.

Program the panel in this order:

1. Set the panel clock.
2. Add (learn) sensors.
3. Set the housecode and light and appliance controls (entry/exit activated lights, sensor-activated lights, time-activated lights).
4. Change options as needed.

Note: If phone lock is on, phone numbers 1 and 2, downloader phone number, account number, phone lock, downloader code, phone report mode 1, phone report modes 1 to 4, access code length, and call waiting and dealer code will not reset to their defaults.

Chapter 5 Testing

This section describes how to perform various test procedures. You should test the system after installing, after servicing, and after adding or removing devices from the system.

In this chapter:

<i>Control panel</i>	56
<i>Sensor testing</i>	57
<i>If a sensor fails the sensor test</i>	58
<i>Phone communication</i>	59
<i>Offsite phone operation</i>	59
<i>Central station communication</i>	60
<i>Two-way voice operation</i>	61
<i>Voice event notification</i>	61
<i>X10 operation</i>	62
<i>Manual lamp module control</i>	62
<i>X10 siren and lamp module functions</i>	62

Control panel

Test the panel by pressing the buttons as described in *Table 26*. *Table 27* provides a list of the arming levels.

Note: An access code is required when arming if the *Secure arming* option is on.

Table 26. Control panel test sequence

Button	Function tested	Test	Correct result
DOORS + WINDOWS	The panel arms door and window sensors.	Press DOORS + WINDOWS button a second time to eliminate the programmed entry delay.	The button will blink when <i>No Entry Delay</i> is on.
MOTIONS	The panel will arm motion sensors.	Press MOTIONS button a second time to turn <i>latchkey</i> on.	The button blinks when <i>latchkey</i> is on.
DISARM	The panel will prompt you to enter an access code.	Enter the appropriate code.	The panel will disarm doors, windows, and motion sensors.
STATUS		Press STATUS button for panel to display and speak the system status.	
POLICE		Press and hold or press button twice quickly to activate a nonmedical, police, or fire emergency alarm.	
FIRE		Press and hold or press button twice quickly to activate a nonmedical, police, or fire emergency alarm.	
EMERGENCY		Press and hold or press button twice quickly to activate a nonmedical, police, or fire emergency alarm.	

Note: Forty key presses for invalid codes (ten invalid 4-digit codes, for example) will cause a system access alarm. The alarm locks all touchpads, except keyfobs, for 90 seconds.

Table 27. Arming levels

Arming level	Description	Indication
0	Subdisarms (master access and duress codes only), and bypasses 24-hour intrusion sensors (master access code only). Fire sensors (group 26) cannot be subdisarmed.	One beep indicates the system is subdisarmed. The panel displays and speaks <i>Subdisarmed</i> . The DISARM button blinks.
1	Disarm the system	One beep indicates the system is disarmed. The panel displays and speaks <i>Disarmed</i> . The DISARM button lights.
2	Arm doors and windows	Two beeps verify that door/window sensors are armed. The panel displays <i>Doors + Windows</i> and speaks <i>Doors and windows on</i> . The DOORS+WINDOWS button lights.
3	Arm motion sensors	Three beeps verify that motion sensors are armed. The panel displays <i>Motions</i> and speaks <i>Motions On</i> . The MOTIONS button lights.
4	Arm doors, windows, and motion sensors	Four beeps verify that door/window and motion sensors are armed. The panel displays <i>Doors + Windows & Motions</i> and speaks <i>Doors and windows on, Motions on</i> . The DOORS+WINDOWS and MOTIONS buttons light.

Sensor testing

Test the sensors after all programming is completed and whenever a sensor-related problem occurs.

Note: While the sensor test is a valuable installation and service tool, it only tests sensor operation for the current conditions. You should perform a sensor test after any change in environment, equipment, or programming.

To test the sensors, do the following:

1. Place all sensors in their secured (no alarm) state.
2. Go to the *Sensor Test* option under the *System Tests* menu, then press **Enter**.

The panel will prompt you to trip each sensor one at a time. You may follow the panel prompting or test the sensors in any order. Use *Table 28* to trip sensors.

Table 28. Sensor tripping instructions

Sensor	Do this
Door/window	Open the secured door or window.
Freeze	Remove the sensor cover. Apply ice in a plastic bag to the sensor (for 10 to 15 minutes). Do not allow the sensor to get wet.
Water	Press a wet rag or wet finger over both of the round, gold-plated terminals on the underside of the sensor.
Carbon monoxide alarm	Unplug the CO Alarm. Plug it back in, wait 5 seconds, then press the TEST/RESET button until the unit beeps 8 times.
Glassbreak	Tap the glass 3 to 4 in. (8 to 10 cm) from the sensor.
Motion sensor	Avoid the motion sensor field of view for five minutes, then enter its view.
Rate-of-rise heat detector	Rub your hands together until warm, then place one hand on the detector for 30 seconds.
Shock	Tap the glass twice, away from the sensor. Wait at least 30 seconds before testing again.
Smoke	Press and hold the test button until the system sounds transmission beeps.
Personal help button	Press and hold the appropriate help button until the light blinks and the panel sounds for at least seven beeps.
Keyfob	Press and hold LOCK and UNLOCK simultaneously for three seconds.
Remote handheld touchpad	Press and hold the two EMERGENCY buttons simultaneously for three seconds.

3. Interior sirens sound transmission beeps, and the display identifies the tripped sensor and the number of RF packets received. Each beep represents one RF packet. Count the number of beeps and refer to *Table 29* for minimum requirements. After the beeps, the panel displays *Sn # Packets=XX Name* (where *XX* equals the number of RF packets and *Name* equals the sensor name). The system will continue to prompt for sensors that have not yet been tested. When all sensors have been tested, the panel will display *Sn Test Complete Press Status*.

Note: If a sensor does not meet the minimum transmission beep requirements, see [If a sensor fails the sensor test](#) on page 58.

Table 29. Minimum beeps

Type of sensor	Number of beeps
Wireless intrusion sensors	7-8
Wireless smoke and heat sensors	7-8
Wireless environmental/panic buttons	7-8
Hardwired loops	1
Emergency buttons (remote handheld touchpads only)	7-8

4. Press **STATUS**. The panel displays *Sensor Test Ok*.
5. If you press **STATUS** and the panel has not heard from all sensors, the panel will display *Sn Test Fail Or Aborted*.

If a sensor fails the sensor test

If sirens do not beep when a sensor is tripped, use an RF Sniffer (60-401) test tool to verify that the sensor is transmitting. Constant beeps from the RF Sniffer indicate a runaway (faulty) sensor. Replace the sensor.

If possible, locate sensors within 100 feet (30 meters) of the panel. While a sensor may have a range of 500 feet (152 meters) or more out in the open, the environment at the installation site can have a significant effect on transmitter range. A change in sensor location may help overcome adverse wireless conditions and can be accomplished by the following:

- Reposition the sensor
- Relocate the sensor
- If necessary, replace the sensor

To reposition a sensor:

1. Rotate the sensor and test for improved sensor communication at 90 and 180 degrees from the original position.
2. If poor communication persists, relocate the sensor.

To relocate a sensor:

1. Test the sensor a few inches from the original position.
2. Increase the distance from the original position and retest until an acceptable location is found.
3. Mount the sensor in the new location.
4. If no location is acceptable, replace the sensor.

To replace a sensor:

1. Test a known good sensor at the same location.
2. If the transmission beeps remain below the minimum level, avoid mounting a sensor at that location.
3. If the known-good sensor functions, contact GE Security for repair or replacement of the problem sensor.

Phone communication

Perform a communication test to check the phone communication between the panel and the central station.

To perform a communication test:

1. Go to the *Comm Test* option under the *System Tests* menu.
2. Press **Enter**. The panel confirms that a communication test has begun. When the communication test is complete, the panel will display *Comm test is OK* within 3 minutes.

If the test is unsuccessful, the **STATUS** button will light and the panel will display *Comm Failure* within 10 minutes.

If the panel displays *Comm Failure*:

1. Check that the panel is connected to the phone jack.
2. Check the phone number programmed into the panel.
3. Perform the communication test again.
4. If the communication test fails again, check the phone connection wiring.

Offsite phone operation

Test the system from a remote phone by calling the panel and using the commands in *Table 30*.

Table 30. Phone commands

System function	Phone command
Disarm	①
Arm doors/windows	②
Arm motion sensors	③
Arm doors/windows with no entry delay	② - ②
Arm motion sensors with latchkey	③ - ③
Arm doors/windows and motion sensors	② - ③
Arm doors/windows with no entry delay and motion sensors with latchkey	② - ② - ③ - ③
Specific light on	* - <unit_num>.
Specific light off	# - <unit_num>.
All lights on	* _ *
All lights off	# - #
System status	①
Audio verification	⑤ + X (X = a command from Audio Verification Set)
Terminate session	⑨

Central station communication

After performing sensor and communication tests, check that the system is reporting alarms successfully to the central station. *Table 31* provides a list of sensor/user report codes.

To test communication with the central station:

1. Call the central station and tell the operator that you will be testing the system.
2. Arm the system.
3. Test each of the wireless panic buttons and trip at least one sensor of each type (fire, intrusion, etc.) to verify that the appropriate alarms are working correctly.
4. When you finish testing the system, call the central station to verify that the alarms were received.

Table 31. Sensor/user report codes

Arm or disarm from	Reports as user
Panel or remote handheld touchpad	0
Keyfob	1 to 40 (sensor number)
Panel aux panic	41
Panel tamper	42
Panel police panic	43
Panel fire panic	44
Dealer access code	44
Installer access code	45
Master code	46
Access codes 1 to 8	47 to 54
Duress code	55

Two-way voice operation

For the central station operator to initiate an audio session:

Note: Panel voice announcements are silenced during AVM sessions. If the operator does not terminate the session correctly, panel announcements may not occur for up to 90 seconds after the operator hangs up.

1. After the panel has completed reporting the alarm, pick up the CS phone and press the * button to start the audio session.
2. Press 1 or 0 to speak, 2 for VOX operation, and 3 or 6 to listen.
3. Press 99 to terminate the session.

Table 32. Audio verification set

Phone buttons	Function
0-1	Speak
2	VOX operation
3 or 6	Listen
7	Extend session for 90 more seconds
88	Terminates session with call back (the panel answers on the first ring if called within 5 minutes)
99	Terminates session with no call back

Voice event notification

Testing this feature requires two people; one at the alarm site and the other at the location the panel is programmed to call.

1. Contact the central monitoring station (if system is monitored) to inform them you are testing the system and not to dispatch authorities.
2. At the system site, put the system into an alarm condition.
3. At the calling location, pick up the phone after it starts ringing. You should hear the panel voice announce *Press star for alarm*.
4. Press * and the panel voice identifies the alarm. If there is more than one alarm in progress, the user must press * for the panel voice to identify them.

Note: You must terminate the call by pressing #. Otherwise, the panel may not disconnect from the phone line for up to 2 minutes.

5. After all alarms have been identified, the panel announces *Press # to exit*.
6. Press # to terminate the call.

X10 operation

The following sections describe how to test X10 lamp, siren, appliance, and universal module operation.

Manual lamp module control

- **Control panel:** Press the asterisk button (*) and the unit number of the lamp module using the numeric buttons to test individual lamp modules 1 through 8. The panel responds with *Light # on/off*. Press the asterisk button (*) twice to turn on all lamp modules. Press the pound button (#) twice to turn off all lamp modules.
- **Keyfob:** Press the **Light** button repeatedly to turn all lights on and off. The panel responds with *Lights on/off*.
- **Remote handheld touchpad:** Press the **Lights on** button and the unit number of the lamp module using the numeric buttons to test individual lamp modules 1 through 8. The panel responds with *Light # on/off*. Pressing the **Lights on** or **off** button twice turns all the lights on or off.

X10 siren and lamp module functions

All sirens turn off when the system is disarmed or when the siren timeout expires. Siren priority is fire (highest priority), intrusion, and emergency. *Table 33* identifies the light information for each of these siren types.

Table 33. Alarm siren and X10 light information

	Fire	Intrusion	Emergency
X10 lights	Steady	Flashing	Steady
X10 siren	Steady	Steady	Alarm beeps
Interior and panel Siren	Temporal 3	Steady	Fast on/off

If an alarm of greater priority occurs during an alarm of lower priority, the greater priority alarm sirens sound. Fire alarms sound a temporal 3 pattern (0.5 seconds on, 0.5 seconds off for three beeps then 1.5 seconds off).

Note: The X10 siren must be set to unit #9 to “hear” emergency alarms and status beeps. To hear emergency alarms only, set to unit #10.

Chapter 6 Troubleshooting and support

This chapter provides information to help you troubleshoot problems, perform simple preventive maintenance procedures, and contact technical support in case you need assistance with your GE equipment.

In this chapter:

- Troubleshooting*64
- Contacting technical support*66
- Online publication library*66

Troubleshooting

This section provides information to help you diagnose and solve various problems that may arise while configuring or using your GE product and offers technical support contacts in case you need assistance. (See [Contacting technical support](#) on page 66.)

System status

To clear STATUS (alarm memory), do the following:

From a disarmed state press **STATUS**, listen to the status message, then press **DISARM**.

The panel displays and announces *Siren 1 failure*.

- Turn the *Hardwired Siren Supervision* option off if a hardwired siren or sensor is not connected.
- Check for the correct end-of-line resistor in *HW1 I/O* circuit.

Panel displays and announces *Low battery*.

- Check that panel backup battery is connected.
- Check panel backup battery voltage. If less than 5.4 volts, replace battery and clear system status message.
- Run sensor test.

The panel displays and announces *RF jam*.

- The control panel has detected RF interference.

The panel displays and announces that a sensor is open.

- See [Sensors](#) on page 65.

The panel displays *Set Time* and announces *System time is not set*.

- Set the system time.

Control panel

The panel displays and announces *Invalid*.

- This sensor is already programmed. Delete sensor if not correctly programmed.

Options (programmable by the homeowner)

The panel does not beep.

- Turn on *Piezo Beeps* option.

Latchkey does not function.

- Latchkey time is not set. Set latchkey time.
- Latchkey is not enabled. Enable latchkey by pressing **MOTIONS** twice.
- The phone number is not programmed properly. Reprogram the phone number.
- System time is not set. Set system time.

Sensors

A sensor does not work.

- Make sure the battery is good and installed correctly.
- Check for interference from metal objects. Move or rotate the sensor.
- Move the sensor to a new location.

Door or window is closed, but the panel announces it is open.

- Be certain the arrow on the magnet and the guide line on the transmitter are aligned and within 1/4 inch of each other.
- The sensor tamper switch may be open (cover off).

Motion sensors go off continuously.

- Be sure the sensor is mounted on a solid surface and the viewing field is free from sources of changing temperature.

Motion sensor does not respond to motion.

- Make sure the sensor battery is good and installed correctly. Wait 2 minutes after installing a new battery to test the sensor.
- Adjust the sensor mounting.
- Leave the area for 3 minutes, then retest.
- The environment is too hot or too cold. Outdoor sensors operate between 32 and 120°F (0 and 49°C).
- Dirt or dust may be causing the problem. Wipe the sensor with a clean, damp cloth.

X10 modules

All lamp modules or siren not working.

- Be sure the panel transformer is plugged into an outlet that is not controlled by a switch.
- Check that the panel is powered using the line carrier power transformer.
- Housecode was programmed incorrectly.

One lamp module or siren is not working.

- Unplug nearby equipment that may be causing interference (light dimmer switches, televisions, appliances with older motors).
- Check that the switch on the lamp or appliance is turned on and remains on.
- Make sure the lamp has a working bulb.
- Make sure the lamp or appliance is plugged into the Lamp/Appliance Module, the Module is plugged into the outlet and the outlet is not controlled by a switch.
- Make sure the House and Unit Codes are correct.
- Move the Module to a different outlet that is on the same phase (branch) of the household electrical circuit as the panel.

Time- or sensor-activated light not working.

- Make sure you have programmed the light to be activated by a timer or sensor.
- Make sure the system clock is set.
- Make sure these functions have been enabled. The functions are enabled if the appropriate icon is shown on the display.

Contacting technical support

For assistance installing, operating, maintaining, and troubleshooting this product, refer to this document and any other documentation provided. If you still have questions, you may contact technical support during normal business hours (Monday through Friday, excluding holidays, between 5 a.m. and 5 p.m. Pacific Time).

Table 34. Service and support contact information

	Customer service	Technical support
Phone	Toll-free: 888.GESECURity (888.437.3287) in the US, including Alaska and Hawaii; Puerto Rico; Canada. Outside the toll-free area: 503.885.5700.	
E-mail	gesecurity.customerservice@ge.com	nstechsrv@ge.com
Fax	888.329.0331	888.329.0332

Note: Be ready at the equipment before calling for technical support.

Online publication library

Another great resource for assistance with your GE product is our online publication library. To access the library, go to our website at the following location:

<http://www.gesecurity.com>

In the **Customer Support** menu, select the *Resource Library* link. After you register and log on, you may search through our online library for the documentation you need.¹

1. Many GE documents are provided as PDFs (portable document format). To read these documents, you will need Adobe Reader, which can be downloaded free from Adobe's website at www.adobe.com.

Appendix A Specifications and tables

This appendix provides a couple lists of sensor names and a quick reference chart for operating the Simon XT system with various peripheral devices.

In this appendix:

<i>Specifications</i>	68
<i>Sensor names</i>	68
<i>Simon XT system quick reference</i>	70

Specifications

Table 35. Simon XT specifications

Requirement	Description
Power	9 VAC, 30 VA transformer
	Rechargeable battery: 6.0 VDC, 1.2 Ah lead-acid. The battery will last 24 hours with no AC and specified standby load.
Radio frequency	319.5 MHz
Storage temperature range	-29 to 140°F (-34 to 60°C)
Operating temperature range	32 to 120°F (0 to 49°C)
Maximum humidity	90% relative humidity, noncondensing
Auxiliary power	Unregulated 5.1 to 12 VDC, power limited to 250 mA (maximum) at 10 VDC
Size (L x W x D)	7 x 5.75 x 2.125 in. (178 x 146 x 54 mm)

Sensor names

Table 36 below and Table 37 on page 69 provide alphabetical and numerically sequential lists of the sensor name segments.

































Table 36. Alphabetical list of sensor name segments

#	Phrase	#	Phrase	#	Phrase
039	Attic	003	Front window	041	Module
004	Back door	028	Garage	024	Office
005	Back window	006	Garage door	025	Office window
030	Basement	007	Garage window	023	Patio door
031	Basement window	012	Guest room	042	Phone module
010	Bedroom	013	Guest room window	021	Porch
011	Bedroom window	036	Hallway	022	Porch window
014	Child's room	000	Keyfob (keychain)	029	Special chime
015	Child's room window	019	Kitchen	040	System panic
038	Closet	020	Kitchen window	001	Touchpad
026	Den	017	Living room	032	Upstairs
027	Den window	018	Living room window	033	Upstairs window
034	Downstairs	008	Master bedroom	016	Utility room
035	Downstairs window	009	Master bedroom window		
002	Front door	037	Medicine cabinet		

Table 37. Sensor name segments by index number (in scrolling order)

#	Phrase	#	Phrase	#	Phrase
000	Keyfob (keychain)	043	A	086	&
001	Touchpad	044	B	087	*
002	Front door	045	C	088	(
003	Front window	046	D	089)
004	Back door	047	E	090	"
005	Back window	048	F	091	-
006	Garage door	049	G	092	_
007	Garage window	050	H	093	+
008	Master bedroom	051	I	094	=
009	Master bedroom window	052	J	095	{
010	Bedroom	053	K	096	}
011	Bedroom window	054	L	097	
012	Guest room	055	M	098	.
013	Guest room window	056	N	099	<
014	Child's room	057	O	100	>
015	Child's room window	058	P	101	?
016	Utility room	059	Q	102	[space]
017	Living room	060	R	103	a
018	Living room window	061	S	104	b
019	Kitchen	062	T	105	c
020	Kitchen window	063	U	106	d
021	Porch	064	V	107	e
022	Porch window	065	W	108	f
023	Patio door	066	X	109	g
024	Office	067	Y	110	h
025	Office window	068	Z	111	i
026	Den	069	0	112	j
027	Den window	070	1	113	k
028	Garage	071	2	114	l
029	Special chime	072	3	115	m
030	Basement	073	4	116	n
031	Basement window	074	5	117	o
032	Upstairs	075	6	118	p
033	Upstairs window	076	7	119	q
034	Downstairs	077	8	120	r
035	Downstairs window	078	9	121	s
036	Hallway	079	/	122	t
037	Medicine Cabinet	080	'	123	u
038	Closet	081	!	124	v
039	Attic	082	@	125	w
040	System panic	083	#	126	x
041	Module	084	\$	127	y
042	Phone module	085	%	128	z

Table 38. Simon XT system quick reference ^a

	Control panel	Remote touchpad	Keyfob	Telephone
Level 0: Subdisarm the system	Enter the master code while the system is disarmed.			①
Level 1: Disarm the system	DISARM , <access_code>.	Disarm 		①
Level 2: Arm doors and windows	DOORS+WINDOWS , <access_code> (if required).	ARM Doors & Windows 		②
Level 3: Arm motion sensors	MOTIONS , <access_code> (if required).	ARM Motion Sensors 		③
Level 4: Arm doors, windows, motions	DOORS+WINDOWS , <access_code> (if required), MOTIONS .	ARM Doors & Windows  - ARM Motion Sensors 	 - 	② - ③
Activate no delay	DOORS+WINDOWS , DOORS+WINDOWS . Appends -No Delay to arming level text.	ARM Doors & Windows  - ARM Doors & Windows 		② - ②
Activate latchkey	MOTIONS , <access_code> (if required), MOTIONS .	ARM Motion Sensors  - ARM Motion Sensors 	 -  - 	③ - ③
Activate panic alarm	Press Fire , Emergency , or Police twice within 3 sec. or hold it for 2 sec.	 +  Hold both for 3 sec.	 +  Hold both for 3 sec.	
Check system status	STATUS	SYSTEM STATUS 		④
Toggle chime or special chime mode	Scroll to <i>Chime</i> or <i>Special Chime</i> , Enter , toggle <i>On/Off</i> , Enter .			
Bypass a sensor	BYPASS , <master_code>, scroll to the sensor, BYPASS .			
Time-activated lights on/off	Scroll to <i>Light Schedules</i> , Enter , toggle <i>On/Off</i> , Enter .			
Sensor-activated lights on/off	Scroll to <i>Sensor Lights</i> , Enter , toggle <i>On/Off</i> , Enter .			
Specific light on	Press *, <unit_num>.	 - <unit_num>.		* - <unit_num>.
Specific light off	Press #, <unit_num>.	 - <unit_num>.		# - <unit_num>.
All lights on	To turn on all lights controlled by lamp modules, press * twice. The panel displays <i>All Lights On</i> .	 - 		* - *
All lights off	To turn off all lights controlled by lamp modules, press # twice. The panel displays <i>All Lights Off</i> .	 - 		# - #

a. A minus sign (-) between buttons means *press one then the next*; a plus sign (+) between buttons means *press both simultaneously*.

Index

A		H	
AC power	27	handheld touchpads	2, 4
access codes	35	hardwired contacts	22
appliance modules	2, 28	hardwired device connections	20
audio verification options	49	housecode	50
autoarm	36		
B		I	
back piece	18, 19	indoor motion sensors	3
backup battery	26	interior siren	21
C		K	
call wait code	39	keyfobs	2, 3
carbon monoxide alarms	3	<i>ELM keyfobs</i>	3
central station communication	60		
clock	34	L	
contrast	34	lamp modules	2, 28
conventions	ix	latchkey	64
cross-zoning	10	light control	50
		line seizure	23
		lock interval	52
D		M	
dial delay	38	menu navigation	32
door/window sensors	2, 3	menu structure	32
downloader code	36	motion sensor	2
DSL	23		
E		O	
emergency button	31	outdoor motion sensors	3
emergency planning	16		
Enterprise Downloader	2, 36	P	
F		panel keys	31
factory defaults	53	panel, back piece	18, 19
fire button	31	panel, mounting	19
firmware revision	34	personal help buttons	4
freeze sensors	3	phone buttons	61
		phone line wiring	23
G		phone numbers	37
GFCI	27	phone options	38
ground fault circuit interrupt	27	piezo beep options	48
		PIR motion sensor	2

planning 6
 police button 31
 power transformer wiring 26
 preface ix
 premises phone 25
 product, overview 2
 program mode 35
 programming 29
 programming codes 35
 publication library 66

Q

quick reference chart 70

R

reports 41
 revision 34

S

safety terms and symbols ix
 secure arming 37
 sensors 39
 deleting 40
 editing 41
 groups 7
 learning 40
 locations 6
 testing 57
 tripping 57
 types 6
 siren options 47

smoke detectors 2, 3
 system components 3
 system menu 31
 system options 46
 system tests 52

T

technical support 66
 testing 55
 timers 44
 touchpad options 45
 tripping sensors 57
 troubleshooting 64
 two-way voice operation 61

U

universal modules 2, 28

V

voice event notification 61

W

water sensors 3

X

X10 modules 3, 28
 X10 operation 50
 X10 testing 62

